

**This electronic collection of documents is provided
for the convenience of the user
and is Not a Certified Document –**

**The documents contained herein were originally issued
and sealed by the individuals whose names and license
numbers appear on each page, on the dates appearing
with their signature on that page.**

**This file or an individual page
shall not be considered a certified document.**

STATE PROJECT: 17BP.10.R.64
CONTRACT: DJ00184

See Sheet 1-A For Index of Sheets

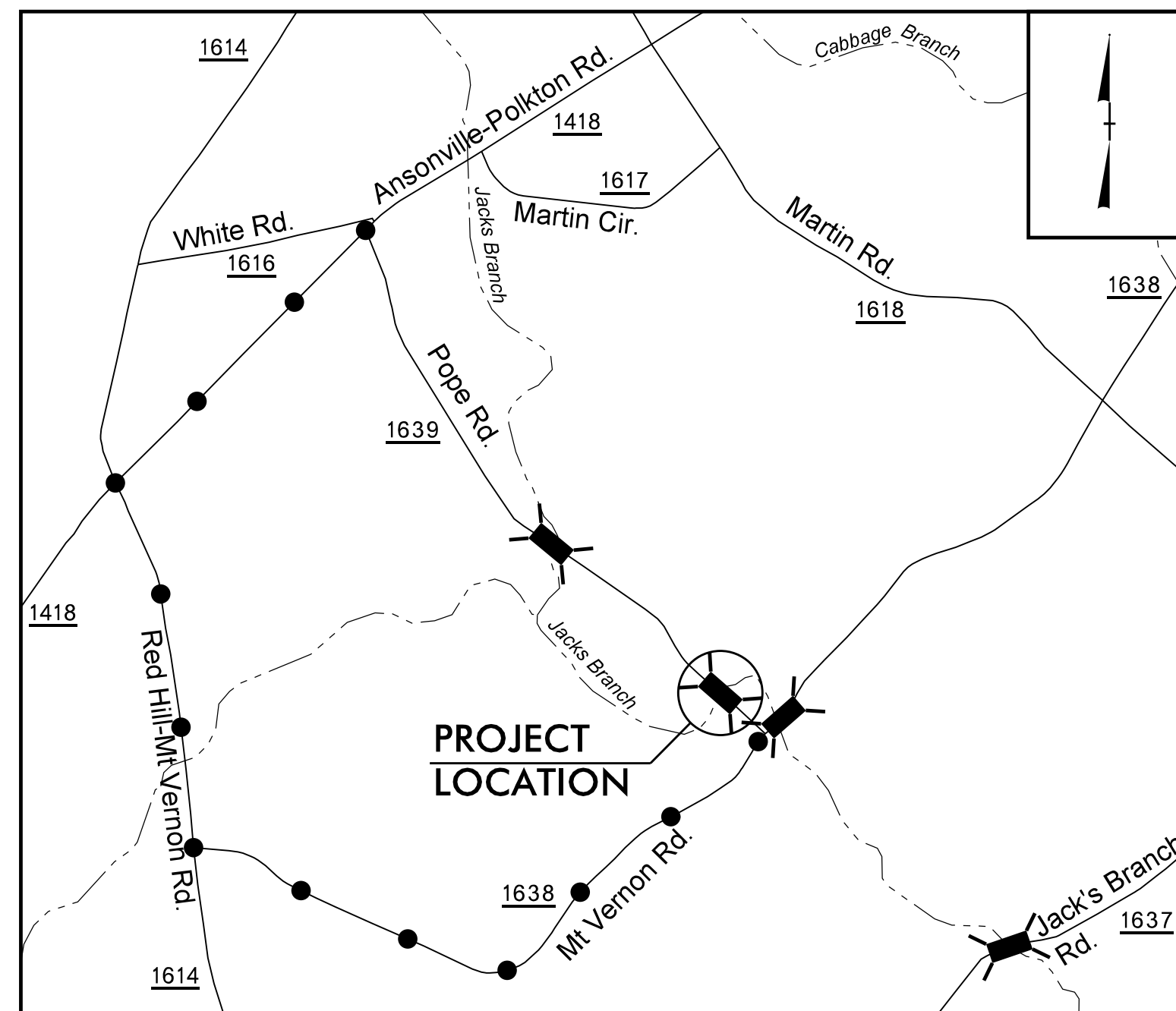

DETOUR ROUTE
VICINITY MAP (NOT TO SCALE)

STATE OF NORTH CAROLINA
 DIVISION OF HIGHWAYS
ANSON COUNTY

**LOCATION: BRIDGE NO. 315 ON SR 1639 OVER JACKS BRANCH
 BETWEEN SR 1418 AND SR 1638**

TYPE OF WORK: GRADING, DRAINAGE, PAVING, AND STRUCTURE

STATE	STATE PROJECT REFERENCE NO.	SHEET NO.	TOTAL SHEETS
N.C.	17BP.10.R.64	1	
STATE PROJ. NO.	F.A. PROJ. NO.	DESCRIPTION	
17BP.10.R.64		P.E., R/W, CONSTR.	

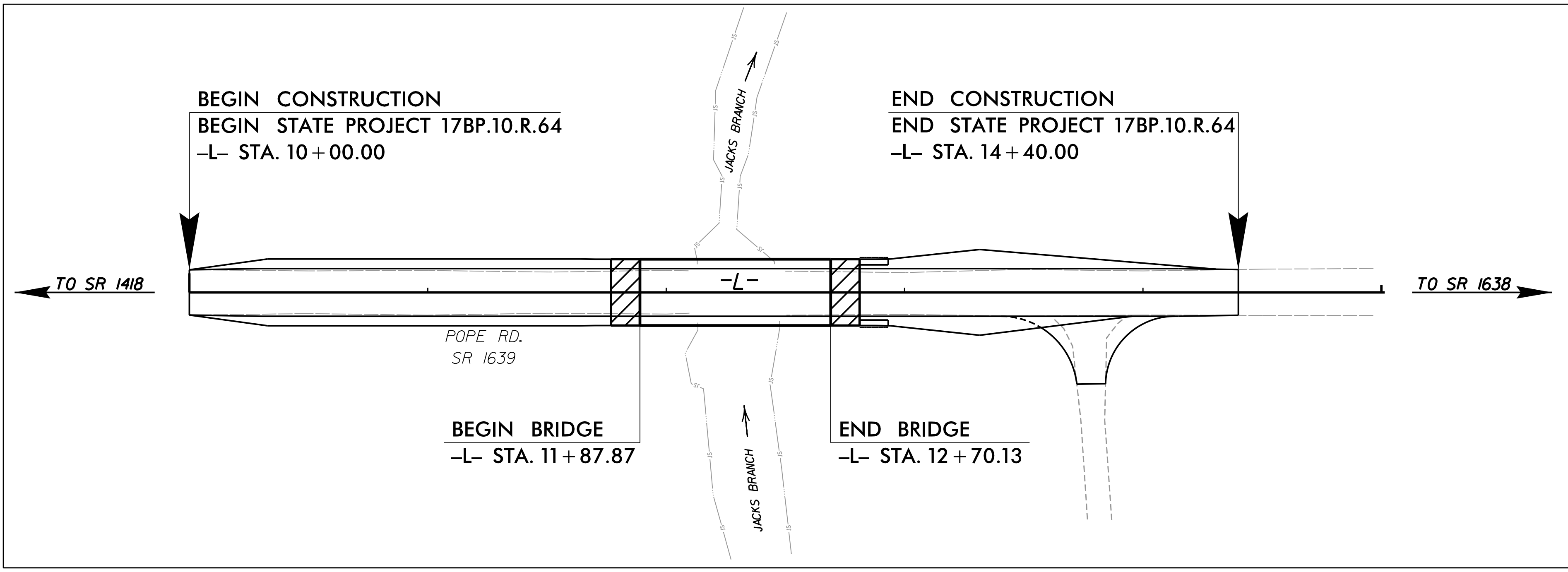
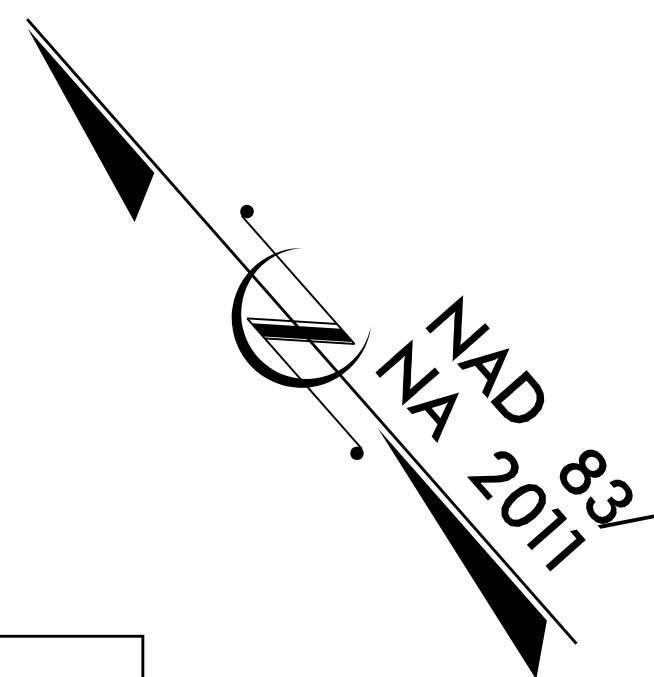

LOCATION SKETCH

HDR HDR Engineering, Inc. of the Carolinas
 555 Fayetteville St, Suite 900 Raleigh, N.C. 27601
 N.C.B.E.L.S. License Number: F-0116

DOCUMENT NOT CONSIDERED FINAL
 UNLESS ALL SIGNATURES COMPLETED

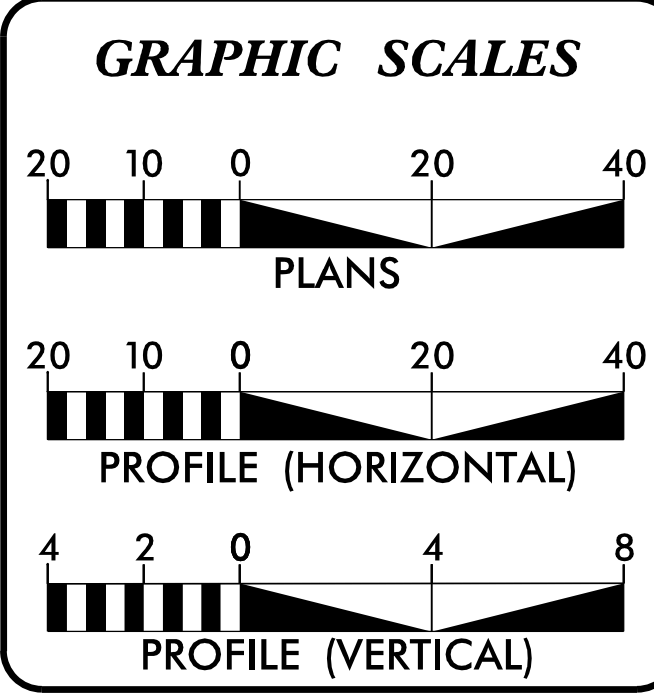

DESIGN DATA

ADT 2000 =	60
ADT 2025 =	100
DHV =	%
D =	%
T =	%
V =	55 MPH
FUNC CLASS =	LOCAL RURAL SUBREGIONAL TIER

PROJECT LENGTH

LENGTH ROADWAY STATE PROJECT 17BP.10.R.64 =	0.068 MILES
LENGTH STRUCTURES STATE PROJECT 17BP.10.R.64 =	0.015 MILES
TOTAL LENGTH STATE PROJECT 17BP.10.R.64 =	0.083 MILES

Prepared for the Office of:
DIVISION OF HIGHWAYS
 1000 Birch Ridge Dr., Raleigh NC, 27610

2012 STANDARD SPECIFICATIONS	
RIGHT OF WAY DATE:	DOMINIC M. WAINWRIGHT, P.E. PROJECT ENGINEER
LETTING DATE:	JAMES R. RICE, P.E. PROJECT DESIGN ENGINEER

HYDRAULICS ENGINEER



James R. Rice
 James R. Rice (Mar 16, 2016)
 SEAL 31986
 P.E.

ROADWAY DESIGN ENGINEER

Domonic M. Wainwright
 Domonic M. Wainwright (Mar 16, 2016)
 SEAL 026441
 P.E.

**DIVISION OF HIGHWAYS
 STATE OF NORTH CAROLINA**

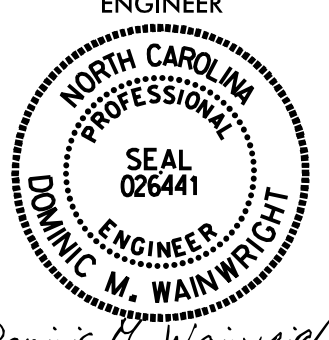
LOUIS MITCHELL
 DIVISION ENGINEER

PROJECT REFERENCE NO. 17BPJ0R64	SHEET NO. 1-A
ROADWAY DESIGN ENGINEER	
	
<i>Dominic M. Wainwright</i> <small>Dominic M. Wainwright (Mar 10, 2014)</small>	
DOCUMENT NOT CONSIDERED FINAL UNLESS ALL SIGNATURES COMPLETED	
 HDR Engineering, Inc. of the Carolinas 555 Fayetteville St, Suite 900 Raleigh, N.C. 27601 N.C.B.E.L.S. License Number: F-0116	

INDEX OF SHEETS	
SHEET NUMBER	SHEET
1	TITLE SHEET
1-A	INDEX OF SHEETS, GENERAL NOTES, AND LIST OF STANDARD DRAWINGS
1-B	CONVENTIONAL SYMBOLS
2	PAVEMENT SCHEDULE AND TYPICAL SECTIONS
2-A	STRUCTURE ANCHOR UNITS DETAIL
3	RIGHT-OF-WAY AREA DATA, SUMMARY OF DRAINAGE QUANTITIES, SUMMARY OF GUARDRAIL
4	PLAN AND PROFILE SHEET
TMP-1 THRU TMP-2	TRAFFIC MANAGEMENT PLAN
SD-01	DETOUR SIGN DESIGN
EC-1 THRU EC-5	EROSION CONTROL PLANS
UC-1 THRU UC-2	UTILITY CONSTRUCTION PLANS
UO-1 THRU UO-2	UTILITIES BY OTHERS PLANS
X-1 THRU X-5	CROSS-SECTIONS
S-1 THRU S-14	STRUCTURE PLANS
	STRUCTURE STANDARD NOTES

EFF. 01-17-2012
REV. 10-30-2012

2012 ROADWAY ENGLISH STANDARD DRAWINGS

The following Roadway Standards as appear in "Roadway Standard Drawings" Highway Design Branch - N. C. Department of Transportation - Raleigh, N. C., Dated January, 2012 are applicable to this project and by reference hereby are considered a part of these plans:

STD.NO.	TITLE
DIVISION 2 - EARTHWORK	
200.02	Method of Clearing - Method II
225.02	Guide for Grading Subgrade - Secondary and Local
225.04	Method of Obtaining Superelevation - Two Lane Pavement
DIVISION 3 - PIPE CULVERTS	
300.01	Method of Pipe Installation
310.10	Driveway Pipe Construction
DIVISION 4 - MAJOR STRUCTURES	
422.11	Reinforced Bridge Approach Fills - Sub Regional Tier
DIVISION 5 - SUBGRADE, BASES AND SHOULDERS	
560.01	Method of Shoulder Construction - High Side of Superelevated Curve - Method I
DIVISION 8 - INCIDENTALS	
840.25	Anchorage for Frames - Brick or Concrete or Precast
840.29	Frames and Narrow Slot Flat Grates
840.35	Traffic Bearing Grated Drop Inlet - for Cast Iron Double Frame and Grates
846.01	Concrete Curb, Gutter and Curb & Gutter
846.04	Drop Inlet Installation in Shoulder Berm Gutter
848.02	Driveway Turnout - Radius Type
862.01	Guardrail Placement
862.02	Guardrail Installation
866.03	Woven Wire Fence - with Steel Post
876.04	Drainage Ditches with Class 'B' Rip Rap

GENERAL NOTES:

2012 SPECIFICATIONS
EFFECTIVE: 01-17-2012
REVISED: 10-31-2014

GRADE LINE:
GRADING AND SURFACING:

THE GRADE LINES SHOWN DENOTE THE FINISHED ELEVATION OF THE PROPOSED SURFACING AT GRADE POINTS SHOWN ON THE TYPICAL SECTIONS. GRADE LINES MAY BE ADJUSTED AT THEIR BEGINNING AND ENDING AND AT STRUCTURES AS DIRECTED BY THE ENGINEER IN ORDER TO SECURE A PROPER TIE-IN.

CLEARING:

CLEARING ON THIS PROJECT SHALL BE PERFORMED TO THE LIMITS ESTABLISHED BY METHOD II.

SUPERELEVATION:

ALL CURVES ON THIS PROJECT SHALL BE SUPERELEVATED IN ACCORDANCE WITH STD. NO. 225.04 USING THE RATE OF SUPERELEVATION AND RUNOFF SHOWN ON THE PLANS. SUPERELEVATION IS TO BE REVOLVED ABOUT THE GRADE POINTS SHOWN ON THE TYPICAL SECTIONS.

SHOULDER CONSTRUCTION:

ASPHALT, EARTH, AND CONCRETE SHOULDER CONSTRUCTION ON THE HIGH SIDE OF SUPERELEVATED CURVES SHALL BE IN ACCORDANCE WITH STD. NO. 560.01

SIDE ROADS:

THE CONTRACTOR WILL BE REQUIRED TO DO ALL NECESSARY WORK TO PROVIDE SUITABLE CONNECTIONS WITH ALL ROADS, STREETS, AND DRIVES ENTERING THIS PROJECT. THIS WORK WILL BE PAID FOR AT THE CONTRACT UNIT PRICE FOR THE PARTICULAR ITEMS INVOLVED.

DRIVEWAYS:

DRIVEWAYS SHALL BE CONSTRUCTED IN ACCORDANCE WITH STD. 848.02 USING 10' RADII OR RADII AS SHOWN ON THE PLANS. LOCATIONS OF DRIVES WILL BE AS SHOWN ON THE PLANS OR AS DIRECTED BY THE ENGINEER.

GUARDRAIL:

THE GUARDRAIL LOCATIONS SHOWN ON THE PLANS MAY BE ADJUSTED DURING CONSTRUCTION AS DIRECTED BY THE ENGINEER. THE CONTRACTOR SHOULD CONSULT WITH THE ENGINEER PRIOR TO ORDERING GUARDRAIL MATERIAL.

END BENTS:

THE ENGINEER SHALL CHECK THE STRUCTURE END BENT PLANS, DETAILS, AND CROSS-SECTION PRIOR TO SETTING OF THE SLOPE STAKES FOR THE EMBANKMENT OR EXCAVATION APPROACHING A BRIDGE.

UTILITIES:

UTILITY OWNERS ON THIS PROJECT ARE WINDSTREAM, PEE DEE EMC, AND ANSON COUNTY. ANY RELOCATION OF EXISTING UTILITIES WILL BE ACCOMPLISHED BY OTHERS, EXCEPT AS SHOWN ON THE PLANS.

RIGHT-OF-WAY MARKERS:

ALL RIGHT-OF-WAY MARKERS ON THIS PROJECT SHALL BE PLACED BY OTHERS.

Note: Not to Scale

*S.U.E. = Subsurface Utility Engineering

CONVENTIONAL PLAN SHEET SYMBOLS

BOUNDARIES AND PROPERTY:

State Line	-----
County Line	-----
Township Line	-----
City Line	-----
Reservation Line	-----
Property Line	-----
Existing Iron Pin	○ _{EP}
Property Corner	-----
Property Monument	□ _{ECM}
Parcel/Sequence Number	⑫③
Existing Fence Line	-x-x-x-
Proposed Woven Wire Fence	○
Proposed Chain Link Fence	□
Proposed Barbed Wire Fence	◇
Existing Wetland Boundary	----- _{WLB}
Proposed Wetland Boundary	----- _{WLB}
Existing Endangered Animal Boundary	----- _{EAB}
Existing Endangered Plant Boundary	----- _{EPB}
Known Soil Contamination: Boundary or Site	☠
Potential Soil Contamination: Boundary or Site	?

BUILDINGS AND OTHER CULTURE:

Gas Pump Vent or U/G Tank Cap	○
Sign	○
Well	○ _W
Small Mine	✕
Foundation	▭
Area Outline	▭
Cemetery	†
Building	▭
School	▭
Church	▭
Dam	▭

HYDROLOGY:

Stream or Body of Water	-----
Hydro, Pool or Reservoir	▭
Jurisdictional Stream	----- _{JS}
Buffer Zone 1	----- _{BZ 1}
Buffer Zone 2	----- _{BZ 2}
Flow Arrow	←
Disappearing Stream	-----
Spring	○
Wetland	-----
Proposed Lateral, Tail, Head Ditch	-----
False Sump	▽

RAILROADS:

Standard Gauge	-----
RR Signal Milepost	○ _{MILEPOST 35}
Switch	□ _{SWITCH}
RR Abandoned	-----
RR Dismantled	-----

RIGHT OF WAY:

Baseline Control Point	◆
Existing Right of Way Marker	△
Existing Right of Way Line	-----
Proposed Right of Way Line	-----
Proposed Right of Way Line with Iron Pin and Cap Marker	-----
Proposed Right of Way Line with Concrete or Granite Marker	-----
Existing Control of Access	○
Proposed Control of Access	○
Existing Easement Line	-----
Proposed Temporary Construction Easement	-----
Proposed Temporary Drainage Easement	-----
Proposed Permanent Drainage Easement	-----
Proposed Permanent Drainage / Utility Easement	-----
Proposed Permanent Utility Easement	-----
Proposed Temporary Utility Easement	-----
Proposed Aerial Utility Easement	-----

ROADS AND RELATED FEATURES:

Proposed Permanent Easement with Iron Pin and Cap Marker	◆
Existing Edge of Pavement	-----
Existing Curb	-----
Proposed Slope Stakes Cut	----- _C
Proposed Slope Stakes Fill	----- _F
Proposed Curb Ramp	○ _{CR}
Curb Cut Future Ramp	○ _{CCFR}

Existing Metal Guardrail	-----
Proposed Guardrail	-----
Existing Cable Guiderail	-----
Proposed Cable Guiderail	-----
Equality Symbol	⊕
Pavement Removal	▨

VEGETATION:

Single Tree	○
Single Shrub	○
Hedge	-----
Woods Line	-----

Orchard	-----
Vineyard	-----

EXISTING STRUCTURES:

MAJOR:	
Bridge, Tunnel or Box Culvert	-----
Bridge Wing Wall, Head Wall and End Wall	-----
MINOR:	
Head and End Wall	-----
Pipe Culvert	-----
Footbridge	-----
Drainage Box: Catch Basin, DI or JB	□ _{CB}
Paved Ditch Gutter	-----
Storm Sewer Manhole	○
Storm Sewer	-----

UTILITIES:

POWER:	
Existing Power Pole	●
Proposed Power Pole	○
Existing Joint Use Pole	●
Proposed Joint Use Pole	○
Power Manhole	⊕
Power Line Tower	⊗
Power Transformer	⊗
U/G Power Cable Hand Hole	□
H-Frame Pole	●
Recorded U/G Power Line	----- _P
Designated U/G Power Line (S.U.E.*)	----- _P

TELEPHONE:

Existing Telephone Pole	●
Proposed Telephone Pole	○
Telephone Manhole	⊕
Telephone Booth	□
Telephone Pedestal	□
Telephone Cell Tower	⊗
U/G Telephone Cable Hand Hole	□
Recorded U/G Telephone Cable	----- _T
Designated U/G Telephone Cable (S.U.E.*)	----- _T
Recorded U/G Telephone Conduit	----- _{TC}
Designated U/G Telephone Conduit (S.U.E.*)	----- _{TC}
Recorded U/G Fiber Optics Cable	----- _{T FO}
Designated U/G Fiber Optics Cable (S.U.E.*)	----- _{T FO}

WATER:

Water Manhole	⊕
Water Meter	○
Water Valve	⊗
Water Hydrant	⊕
Recorded U/G Water Line	-----
Designated U/G Water Line (S.U.E.*)	-----
Above Ground Water Line	----- _{A/G Water}

TV:

TV Satellite Dish	☾
TV Pedestal	□
TV Tower	⊗
U/G TV Cable Hand Hole	□
Recorded U/G TV Cable	----- _{TV}
Designated U/G TV Cable (S.U.E.*)	----- _{TV}
Recorded U/G Fiber Optic Cable	----- _{TV FO}
Designated U/G Fiber Optic Cable (S.U.E.*)	----- _{TV FO}

GAS:

Gas Valve	◇
Gas Meter	⊕
Recorded U/G Gas Line	----- _G
Designated U/G Gas Line (S.U.E.*)	----- _G
Above Ground Gas Line	----- _{A/G Gas}

SANITARY SEWER:

Sanitary Sewer Manhole	⊕
Sanitary Sewer Cleanout	⊕
U/G Sanitary Sewer Line	----- _{SS}
Above Ground Sanitary Sewer	----- _{A/G Sanitary Sewer}
Recorded SS Forced Main Line	----- _{FSS}
Designated SS Forced Main Line (S.U.E.*)	----- _{FSS}

MISCELLANEOUS:



Utility Pole	●
Utility Pole with Base	□
Utility Located Object	○
Utility Traffic Signal Box	□
Utility Unknown U/G Line	----- _{UTIL}
U/G Tank; Water, Gas, Oil	▭
Underground Storage Tank, Approx. Loc.	⊕ _{UST}
A/G Tank; Water, Gas, Oil	▭
Geoenvironmental Boring	⊗
U/G Test Hole (S.U.E.*)	⊕
Abandoned According to Utility Records	AATUR
End of Information	E.O.I.

8/17/99

PAVEMENT SCHEDULE

C1	PROP. APPROX. 1.5" ASPHALT CONCRETE SURFACE COURSE, TYPE S9.5B, AT AN AVERAGE RATE OF 168 LBS PER SQUARE YARD.
C2	PROP. VAR. DEPTH ASPHALT CONCRETE SURFACE COURSE, TYPE S9.5B, AT AN AVERAGE RATE OF 112 LBS. PER SQ. YD. PER 1" DEPTH TO BE PLACED IN LAYERS NOT TO EXCEED 2.0" IN DEPTH.
D1	PROP. APPROX. 3.5" ASPHALT CONCRETE INTERMEDIATE COURSE, TYPE I19.0B, AT AN AVERAGE RATE OF 399 LBS PER SQUARE YARD.
E1	PROP. APPROX. 4" ASPHALT CONCRETE BASE COURSE, TYPE B25.0B, AT AN AVERAGE RATE OF 456 LBS PER SQUARE YARD.
T	EARTH MATERIAL

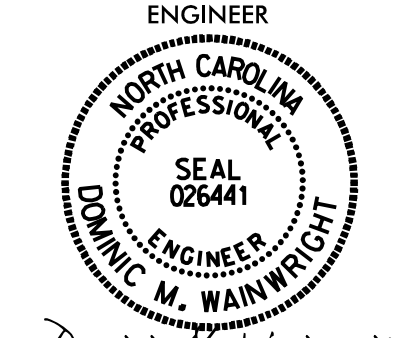
NOTE: PAVEMENT EDGE SLOPES ARE 1:1 UNLESS OTHERWISE SHOWN.

PROJECT REFERENCE NO. 17BP.10.R.64	SHEET NO. 2
RW SHEET NO.	
ROADWAY DESIGN ENGINEER	
	
<i>Dominic M. Wainwright</i> Dominic M. Wainwright (Mar 16, 2010)	
DOCUMENT NOT CONSIDERED FINAL UNLESS ALL SIGNATURES COMPLETED	
 HDR Engineering, Inc. of the Carolinas 555 Fayetteville St. Suite 900 Raleigh, N.C. 27601 N.C.B.E.L.S. License Number: F-0116	

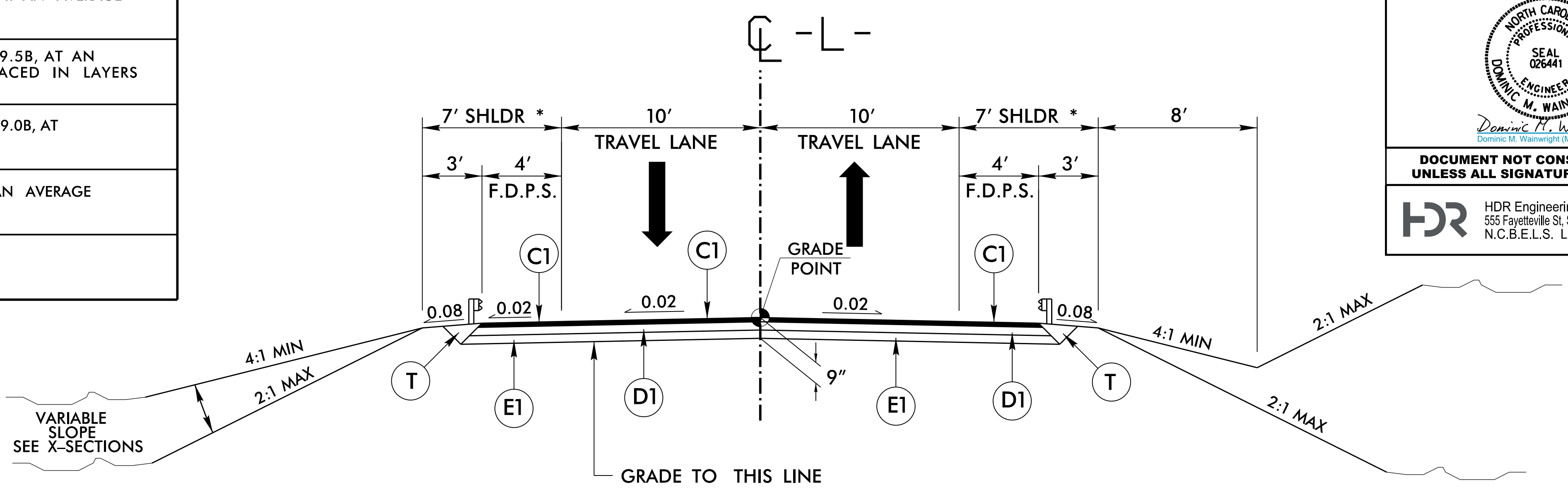

F.D.P.S. = FULL DEPTH PAVED SHOULDER
 * USE 4' TOTAL TURF SHOULDER WIDTH WITHOUT GUARDRAIL

TYPICAL SECTION NO. 1

LINE	FROM STATION	TO STATION
-L-	10 + 00.00	11 + 76.87
-L-	12 + 81.13	14 + 40.00

REVISIONS

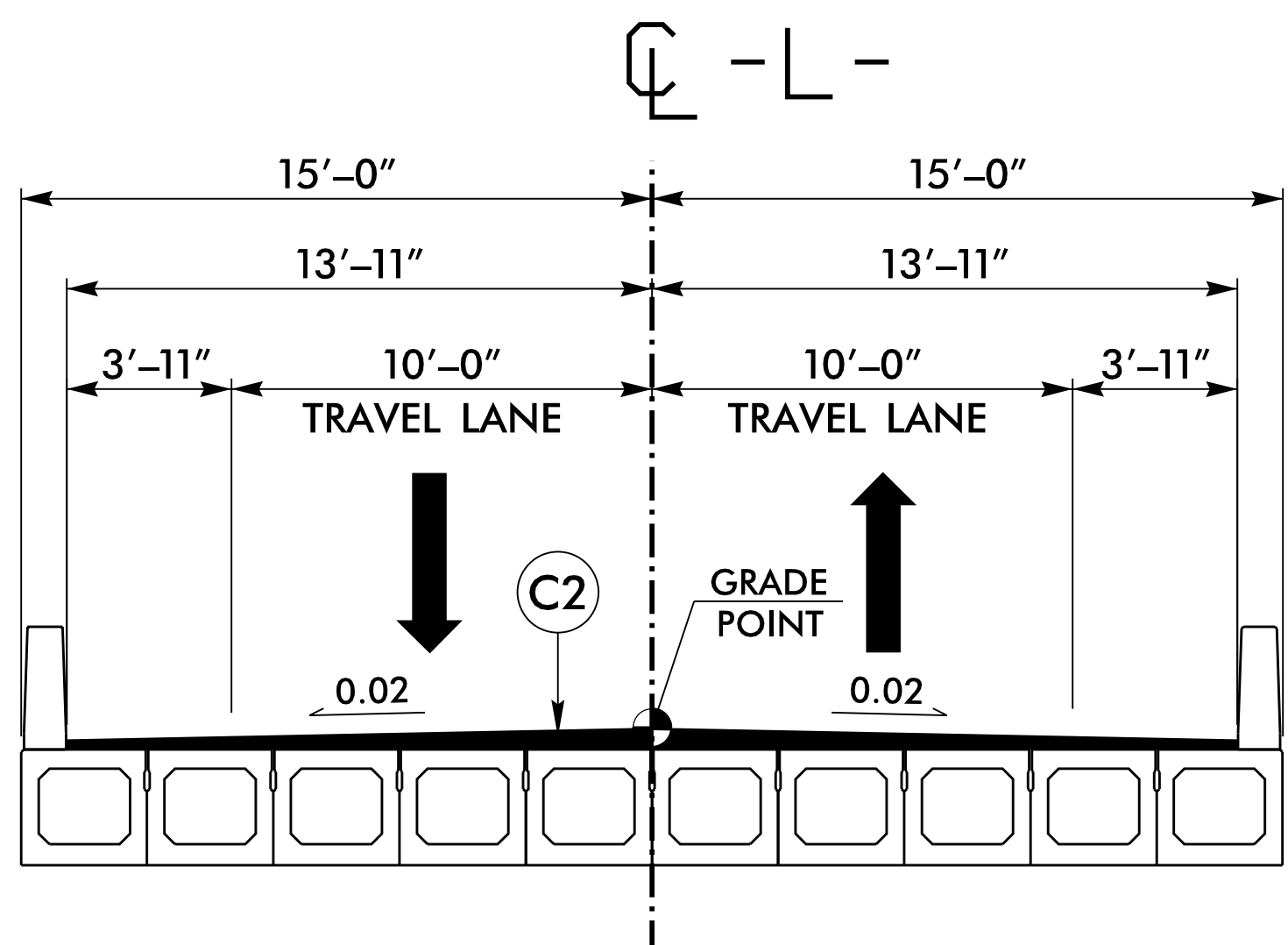

TYPICAL SECTION NO. 2 BOX BEAM BRIDGE

LINE	FROM STATION	TO STATION
-L-	11 + 87.87	12 + 70.13

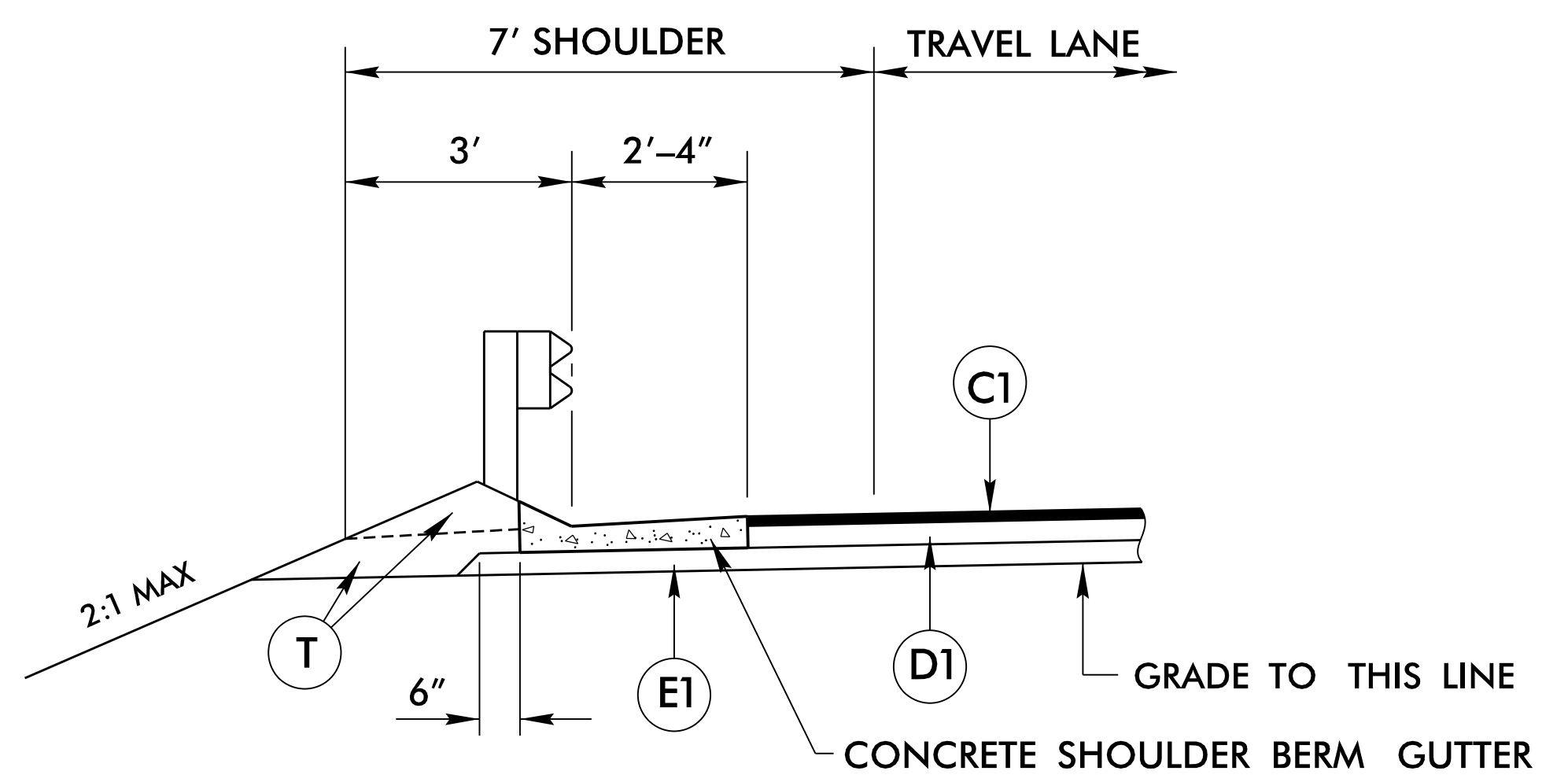

SHOULDER BERM GUTTER DETAIL

USE IN CONJUNCTION WITH TYPICAL SECTION NO. 1

LINE	FROM STATION	TO STATION
-L-	12 + 81.13	12 + 93.13

2/23/2016 7:06:16 AM 17BP-10R64-RDY_TYP.DGN

STATE OF NORTH CAROLINA DEPT. OF TRANSPORTATION DIVISION OF HIGHWAYS RALEIGH, N.C.

ENGLISH DETAIL DRAWING FOR STRUCTURE ANCHOR UNITS GUARDRAIL ANCHOR UNIT, TYPE III FOR ATTACHMENT TO RAIL ON BRIDGE - SUB REGIONAL TIER

SHEET 2 OF 7 862d03

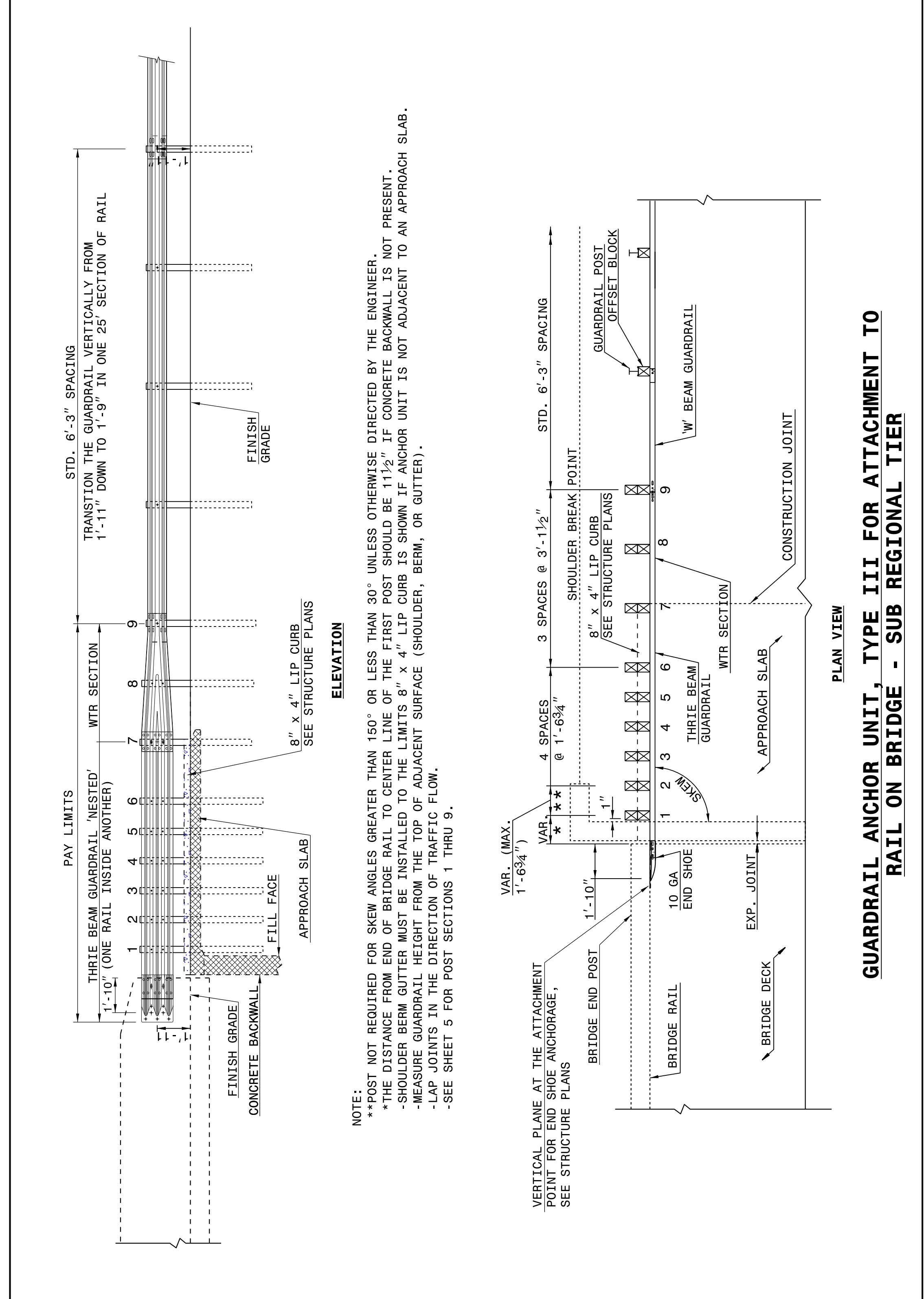

STATE OF NORTH CAROLINA DEPT. OF TRANSPORTATION DIVISION OF HIGHWAYS RALEIGH, N.C.

ENGLISH DETAIL DRAWING FOR STRUCTURE ANCHOR UNITS GUARDRAIL ANCHOR UNIT, TYPE III FOR ATTACHMENT TO RAIL ON BRIDGE - SUB REGIONAL TIER

SHEET 2 OF 7 862d03

STATE OF NORTH CAROLINA DEPT. OF TRANSPORTATION DIVISION OF HIGHWAYS RALEIGH, N.C.

ENGLISH DETAIL DRAWING FOR STRUCTURE ANCHOR UNITS GUARDRAIL ANCHOR UNIT, TYPE III

SHEET 3 OF 7 862d03

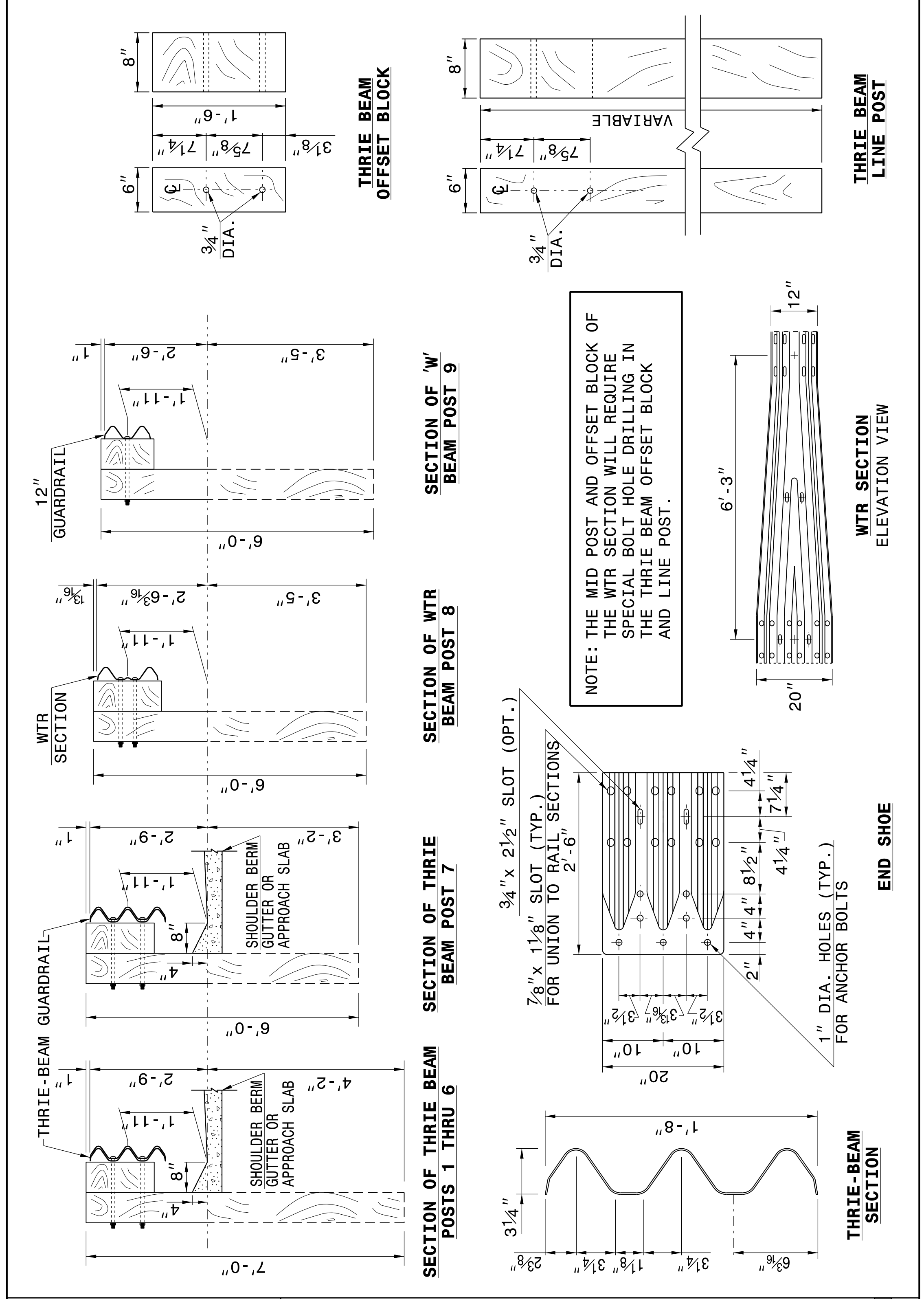

STATE OF NORTH CAROLINA DEPT. OF TRANSPORTATION DIVISION OF HIGHWAYS RALEIGH, N.C.

ENGLISH DETAIL DRAWING FOR STRUCTURE ANCHOR UNITS GUARDRAIL ANCHOR UNIT, TYPE III

SHEET 3 OF 7 862d03

CONTRACT STANDARDS AND DEVELOPMENT UNIT
Office 919-707-6950 FAX 919-250-4119

SEE TITLE BLOCK

ORIGINAL BY: J. HOWERTON DATE: 06-22-12
 MODIFIED BY: DATE:
 CHECKED BY: DATE:
 FILE SPEC.:

\$\$\$\$SYTIME\$\$\$\$
 \$\$\$SYSDATE\$\$\$\$
 \$\$\$SYSDRAWINGNO\$\$\$\$
 \$\$\$SYSDRAWINGNAME\$\$\$\$

DATUM DESCRIPTION

THE LOCALIZED COORDINATE SYSTEM DEVELOPED FOR THIS PROJECT IS BASED ON THE STATE PLANE COORDINATES ESTABLISHED BY NCOS FOR MONUMENT "GPS 315-2" WITH NAD 83/NA 2011 STATE PLANE GRID COORDINATES OF NORTHING: 484983.158(ft) EASTING: 1657851.278(ft) ELEVATION: 258.89(ft) THE AVERAGE COMBINED GRID FACTOR USED ON THIS PROJECT (GROUND TO GRID) IS: 0.99986979 THE N.C. LAMBERT GRID BEARING AND LOCALIZED HORIZONTAL GROUND DISTANCE FROM "GPS 315-2" TO -L- STATION 10+00.00 IS N 40° 10' 56.90" W 82.67' ALL LINEAR DIMENSIONS ARE LOCALIZED HORIZONTAL DISTANCES VERTICAL DATUM USED IS NAVD 88

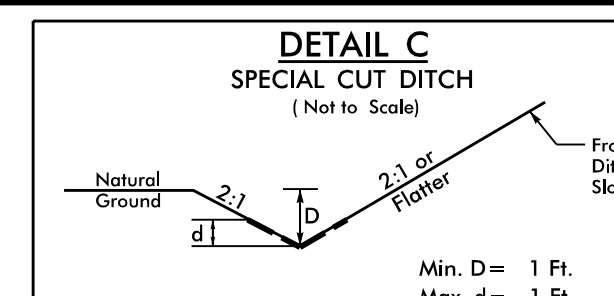
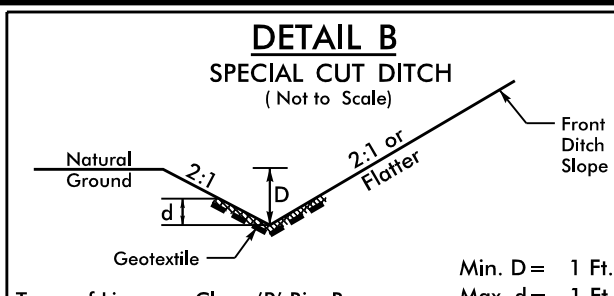
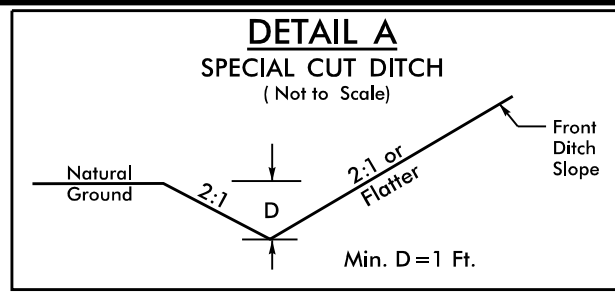

PROJECT REFERENCE NO. 17BP.JO.R.64 SHEET NO. 4

RW SHEET NO.

ROADWAY DESIGN ENGINEER: STEVE E. AND NICOLE H. CARPENTER DB 709 PG 26 PB A-203 PG 2

HYDRAULICS ENGINEER: JAMES R. RICE SEAL 31986

DOMINIC M. WAINWRIGHT SEAL 026441

DOCUMENT NOT CONSIDERED FINAL UNLESS ALL SIGNATURES COMPLETED

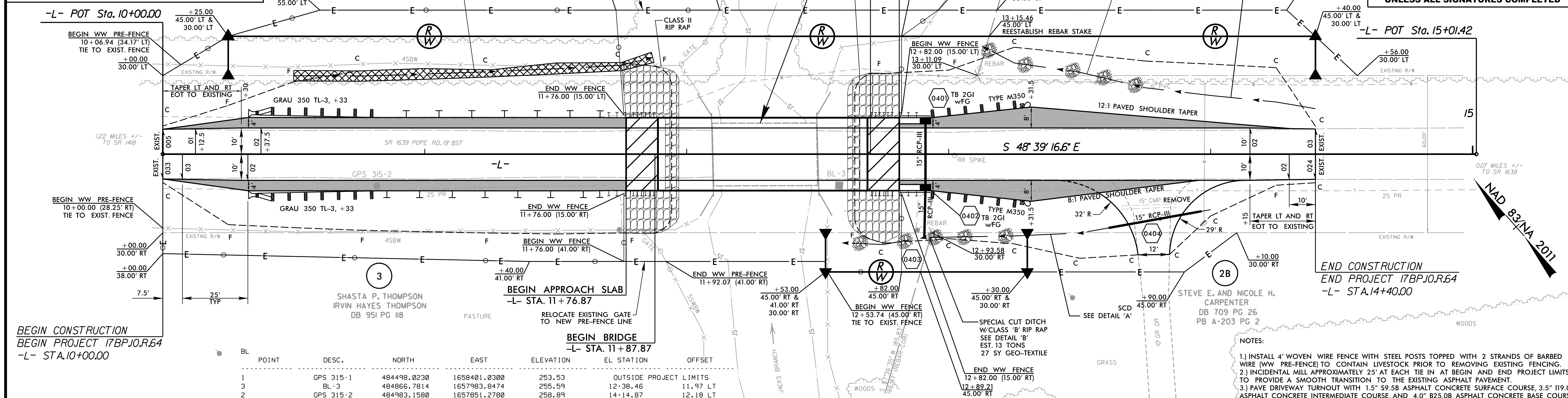

BEGIN CONSTRUCTION
BEGIN PROJECT 17BP.JO.R.64
-L- STA. 10+00.00

END CONSTRUCTION
END PROJECT 17BP.JO.R.64
-L- STA. 14+40.00

POINT	DESC.	NORTH	EAST	ELEVATION	EL STATION	OFFSET
1	GPS 315-1	484498.0230	1658401.0300	253.53		OUTSIDE PROJECT LIMITS
3	BL-3	484866.7814	1657983.8474	255.59	12+38.46	11.97 LT
2	GPS 315-2	484983.1580	1657851.2780	258.89	14+14.87	12.18 LT

- NOTES:
- 1) INSTALL 4' WOVEN WIRE FENCE WITH STEEL POSTS TOPPED WITH 2 STRANDS OF BARBED WIRE (WW PRE-FENCE) TO CONTAIN LIVESTOCK PRIOR TO REMOVING EXISTING FENCING.
 - 2) INCIDENTAL MILL APPROXIMATELY 25' AT EACH TIE IN AT BEGIN AND END PROJECT LIMITS TO PROVIDE A SMOOTH TRANSITION TO THE EXISTING ASPHALT PAVEMENT.
 - 3) PAVE DRIVEWAY TURNOUT WITH 1.5" S9.5B ASPHALT CONCRETE SURFACE COURSE, 3.5" I19.0B ASPHALT CONCRETE INTERMEDIATE COURSE, AND 4.0" B25.0B ASPHALT CONCRETE BASE COURSE.

HDR Engineering, Inc. of the Carolinas
555 Fayetteville St. Suite 900 Raleigh, N.C. 27601
N.C.B.E.L.S. License Number: F-0116

BRIDGE HYDRAULIC DATA

DESIGN DISCHARGE = 1200 CFS
 DESIGN FREQUENCY = 25 YRS
 DESIGN HW ELEVATION = 251.8 FT
 BASE DISCHARGE = 1700 CFS
 BASE FREQUENCY = 100 YRS
 BASE HW ELEVATION = 252.51 FT
 OVERTOPPING DISCHARGE = 5150 CFS
 OVERTOPPING FREQUENCY = 500 + YRS
 OVERTOPPING ELEVATION = 256.9 FT

DATE OF SURVEY = 1/10/2013
 W.S. ELEVATION AT DATE OF SURVEY = 246.6 FT

BL-3
 -L- STA. 12+38.46 (11.97' LEFT)
 -L- STA. 12+58.17 (11.97' RIGHT)
 ELEVATION = 255.59'

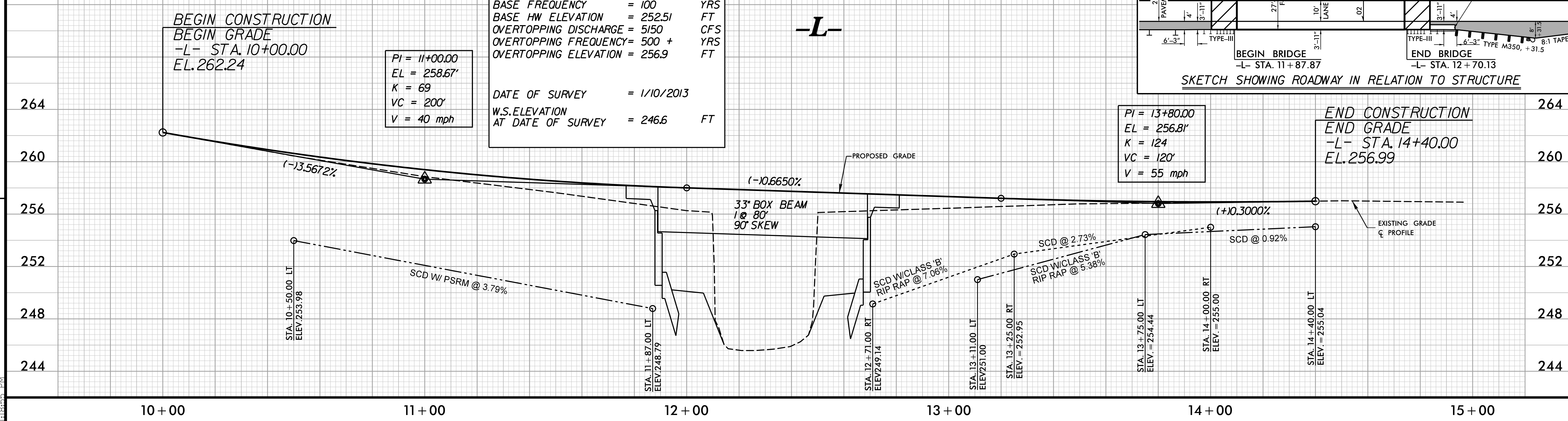
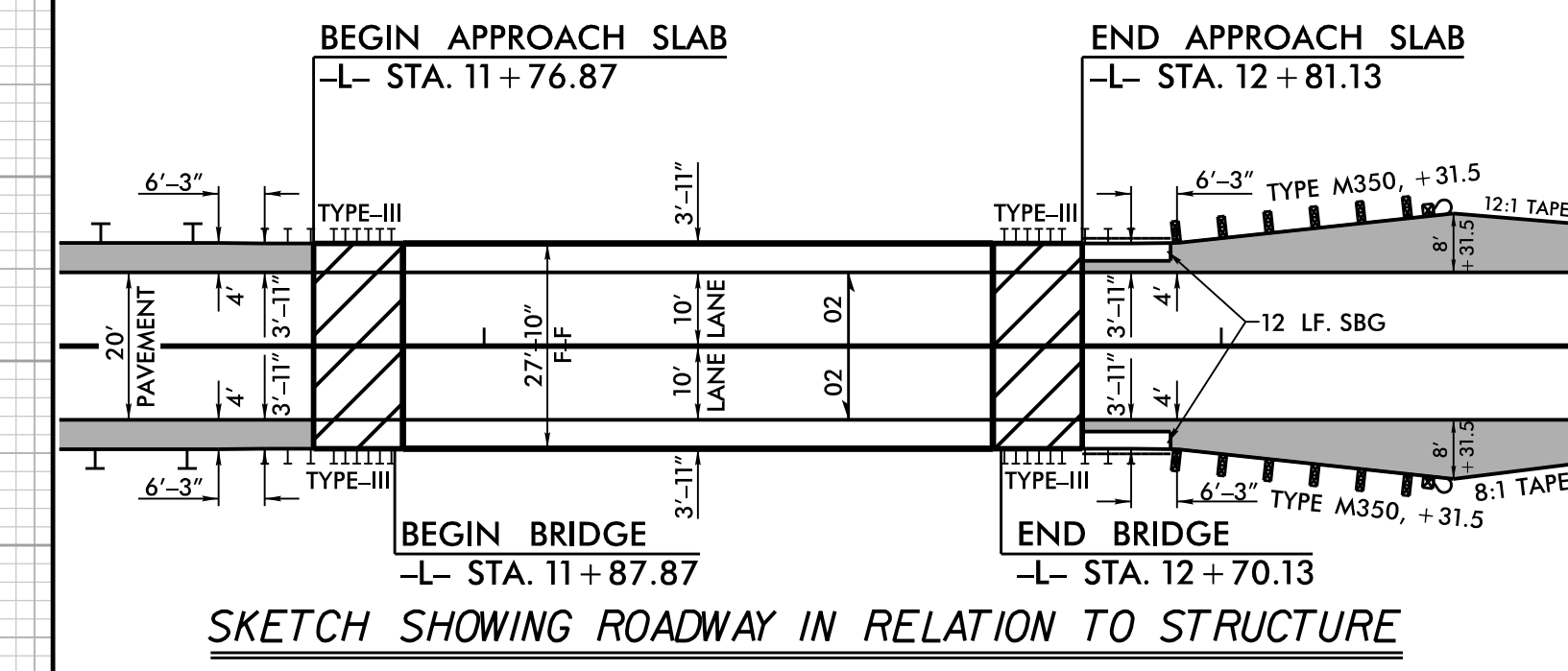

2/23/2016 7:07:10 AM 17BP-10R64-ROY_PSH4.DGN

STATE OF NORTH CAROLINA
DIVISION OF HIGHWAYS

TRANSPORTATION MANAGEMENT PLAN

ANSON COUNTY

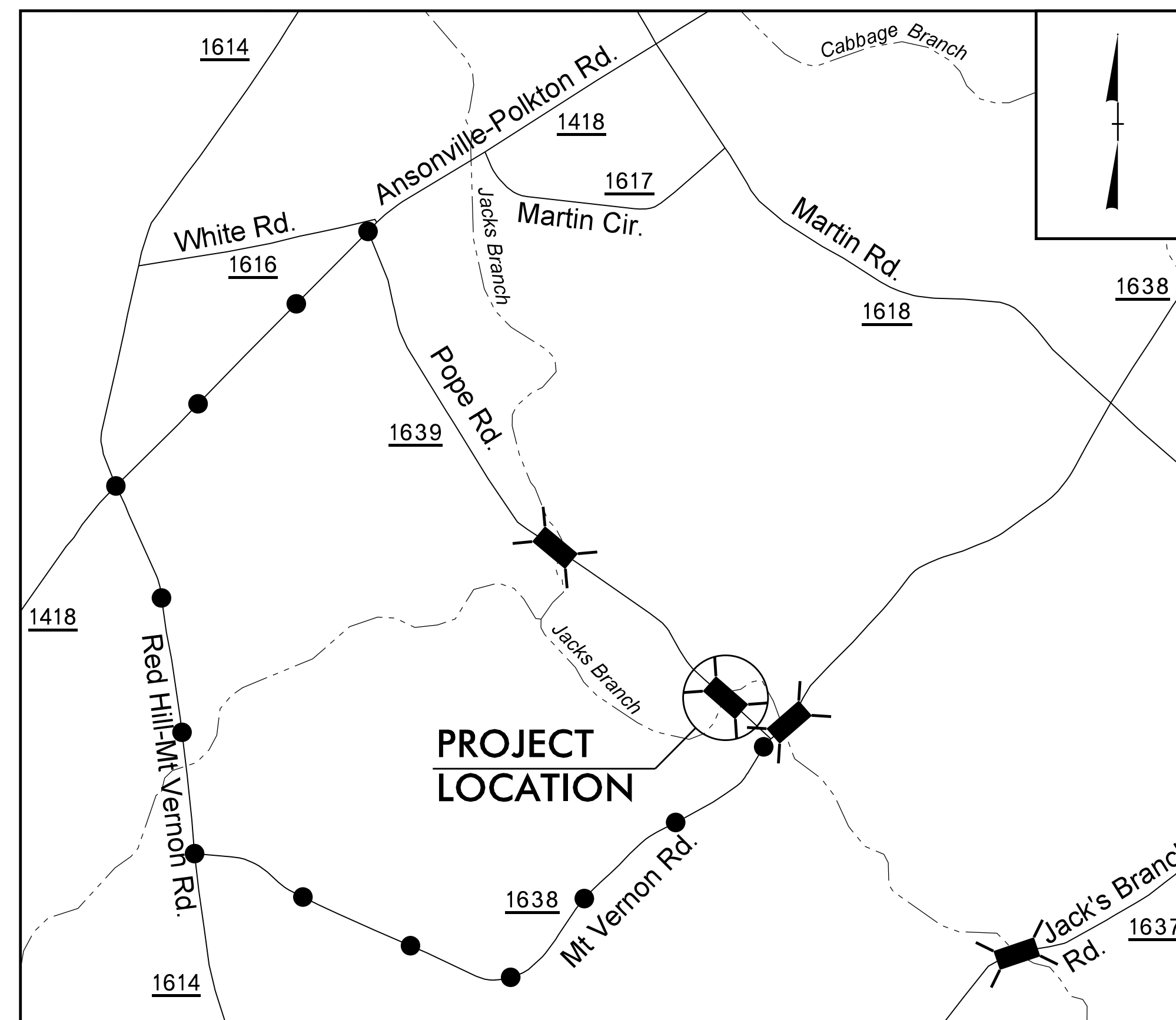
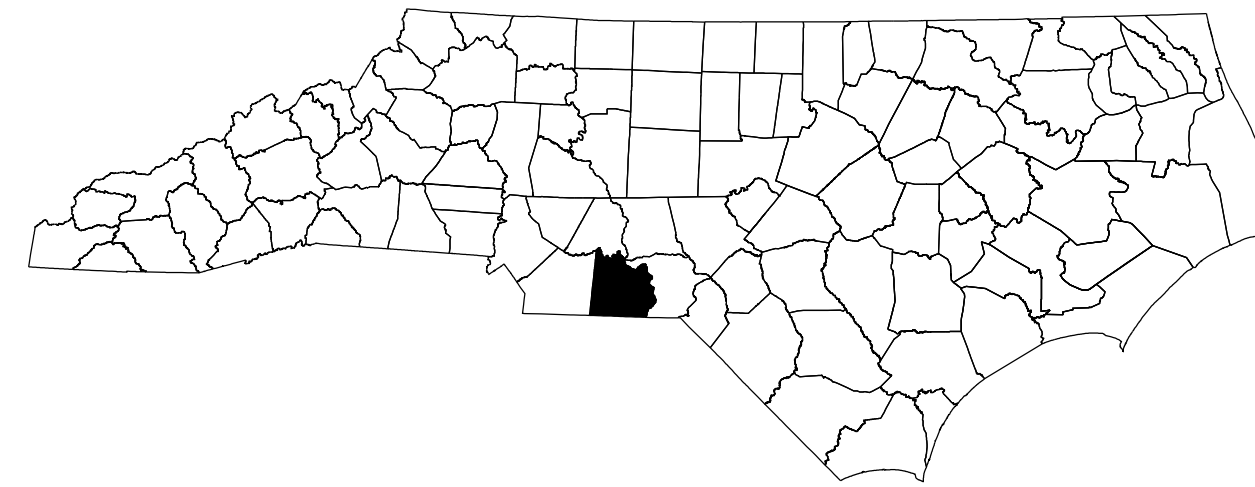

● — ●
DETOUR ROUTE

VICINITY MAP
(NOT TO SCALE)

INDEX OF SHEETS

<u>SHEET NO.</u>	<u>TITLE</u>
TMP-1	TITLE SHEET AND INDEX OF SHEETS
TMP-1A	LIST OF APPLICABLE ROADWAY STANDARD DRAWINGS AND LEGEND
TMP-1B	GENERAL NOTES AND PHASING
TMP-2	OFFSITE DETOUR PLAN - POPE ROAD (SR 1639)
SD-01	SIGN DESIGN - POPE ROAD

SHEET NO.
TMP-1

STATE PROJECT: 17BP.10.R.64

STATE PROJECT: 17BP.10.R.64

PLOT DRIVER: NCDOT_paf_color_eng_50.plt
PENTABLE: NCDOT_tcp.tbl
USER: DWAINWRI
DATE: 2/23/2016
TIME: 14:35:55 PM
FILE: dw\WPAPP\PA01\SouthEast_Tampa_Documents\000166\CON082236\00000000221869\06.00_TIP_Folder_Structure\17BP.10.R.64\TrafficControl\TCP\17BP.10R64_TCP_DSN.dgn

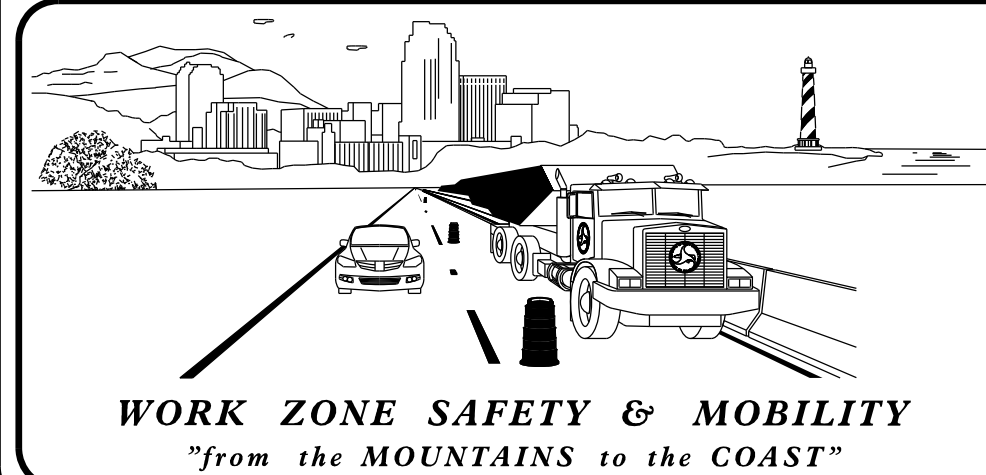

N.C.D.O.T. WORK ZONE TRAFFIC CONTROL
1561 MAIL SERVICE CENTER (MSC) RALEIGH, NC 27699-1561
750 N. GREENFIELD PARKWAY, GARNER, NC 27529 (DELIVERY)
PHONE: (919) 773-2800 FAX: (919) 771-2745

J. S. BOURNE, P.E. STATE TRAFFIC MANAGEMENT ENGINEER
DOMINIC WAINWRIGHT, P.E. ROADWAY PROJECT ENGINEER
MICHELLE WARD, P.E. TRAFFIC CONTROL PROJECT DESIGN ENGINEER
T. N. BEDENBAUGH, E.I. TRAFFIC CONTROL DESIGN ENGINEER



**DOCUMENT NOT CONSIDERED FINAL
UNLESS ALL SIGNATURES COMPLETED**

APPROVED: *Michelle Ward*
Michelle Ward (Feb 23, 2016)

DATE: Feb 29, 2016

HDR Engineering, Inc. of the Carolinas
555 Fayetteville St, Suite 900, Raleigh, N.C. 27601
N.C.B.E.L.S. License Number: F-0116

SEAL







ROADWAY STANDARD DRAWINGS

THE FOLLOWING ROADWAY STANDARDS AS SHOWN IN "ROADWAY STANDARD DRAWINGS" - PROJECT SERVICES UNIT - N.C. DEPARTMENT OF TRANSPORTATION - RALEIGH, N.C., DATED JANUARY 2012 ARE APPLICABLE TO THIS PROJECT AND BY REFERENCE HEREBY ARE CONSIDERED A PART OF THESE PLANS:



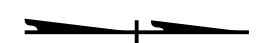





<u>STD. NO.</u>	<u>TITLE</u>
1101.01	WORK ZONE WARNING SIGNS
1101.03	TEMPORARY ROAD CLOSURES
1101.11	TRAFFIC CONTROL DESIGN TABLES
1110.01	STATIONARY WORK ZONE SIGNS
1145.01	BARRICADES
1261.01	GUARDRAIL AND BARRIER DELINEATORS - INSTALLATION SPACING
1261.02	GUARDRAIL AND BARRIER DELINEATORS - TYPES AND MOUNTING
1262.01	GUARDRAIL END DELINEATION

LEGEND

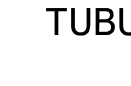
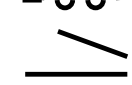
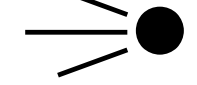

GENERAL

-  DIRECTION OF TRAFFIC FLOW
-  DIRECTION OF PEDESTRIAN TRAFFIC FLOW
-  EXIST. PVMT.
-  NORTH ARROW
-  PROPOSED PVMT.
-  WORK AREA
-  REMOVAL

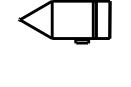
TRAFFIC CONTROL DEVICES

-  BARRICADE (TYPE III)
-  CONE
-  DRUM  SKINNY DRUM  TUBULAR MARKER
-  TEMPORARY CRASH CUSHION
-  FLASHING ARROW PANEL (TYPE C)
-  FLAGGER
-  LAW ENFORCEMENT
-  TRUCK MOUNTED IMPACT ATTENUATOR (TMIA)
-  CHANGEABLE MESSAGE SIGN

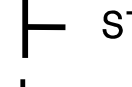
TEMPORARY SIGNING

-  PORTABLE SIGN
-  STATIONARY SIGN
-  STATIONARY OR PORTABLE SIGN

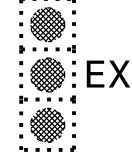
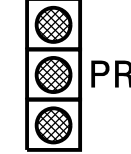
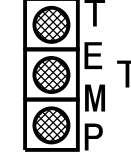

SIGNALS

-  EXISTING
-  PROPOSED
-  TEMPORARY

PAVEMENT MARKINGS

-  EXISTING LINES
-  TEMPORARY LINES

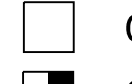
PAVEMENT MARKERS

-  CRYSTAL/CRYSTAL
-  CRYSTAL/RED
-  YELLOW/YELLOW

PAVEMENT MARKING SYMBOLS

-  PAVEMENT MARKING SYMBOLS

PLOT DRIVER: NCDOT_paf_color_eng_50.plt PENTABLE: NCDOT_tcp.tbl
 USER: DWAINWRI DATE: 2/23/2016 TIME: 1:43:56 PM
 FILE: dw:\PWPPTPA01\SouthEast_Tampa\Documents\000166\CON082236\00000000221869\06.00_TIP_Folder_Structure\17BP.10.R.64\TrafficControl\TCP\17BP-10R64_TCP_DSN.dgn

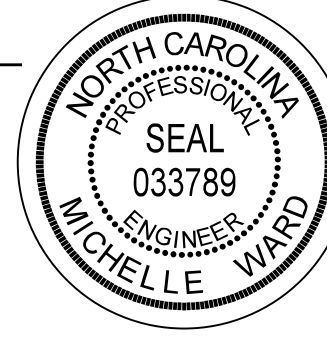
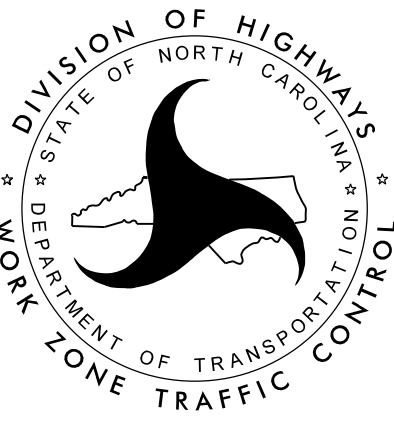
APPROVED:  <small>Michelle Ward (F-0116-10116)</small> DATE: Feb 29, 2016			<h2 style="margin: 0;">ROADWAY STANDARD DRAWINGS & LEGEND</h2>
DOCUMENT NOT CONSIDERED FINAL UNLESS ALL SIGNATURES COMPLETED			

GENERAL NOTES

CHANGES MAY BE REQUIRED WHEN PHYSICAL DIMENSIONS IN THE DETAIL DRAWINGS, STANDARD DETAILS, AND ROADWAY DETAILS ARE NOT ATTAINABLE TO MEET FIELD CONDITIONS, OR RESULT IN DUPLICATE, OR UNDESIRED OVERLAPPING OR DEVICES. MODIFICATION MAY INCLUDE: MOVING, SUPPLEMENTING, COVERING, OR REMOVAL OF DEVICES, AS DIRECTED BY THE ENGINEER.

THE FOLLOWING GENERAL NOTES APPLY AT ALL TIMES FOR THE DURATION OF THE CONSTRUCTION PROJECT, EXCEPT WHEN OTHERWISE NOTED IN THE PLAN, OR DIRECTED BY THE ENGINEER.

TRAFFIC PATTERN ALTERATIONS

- A) NOTIFY THE ENGINEER TWENTY ONE (21) CALENDAR DAYS PRIOR TO ANY TRAFFIC PATTERN ALTERATION.

SIGNING

- B) INSTALL ADVANCE WORK ZONE WARNING SIGNS WHEN WORK IS WITHIN 40 FT FROM THE EDGE OF TRAVEL LANE AND NO MORE THAN THREE (3) DAYS PRIOR TO THE BEGINNING OF CONSTRUCTION.

- C) PROVIDE SIGNING AND DEVICES REQUIRED TO CLOSE THE ROAD ACCORDING TO THE ROADWAY STANDARD DRAWINGS AND TRAFFIC CONTROL PLANS.

PROVIDE SIGNING REQUIRED FOR THE OFFSITE DETOUR ROUTE AS SHOWN IN THE TRAFFIC CONTROL PLANS.

- D) COVER OR REMOVE ALL SIGNS AND DEVICES REQUIRED TO CLOSE THE ROAD WHEN THE ROAD CLOSURE IS NOT IN OPERATION.

COVER OR REMOVE ALL SIGNS REQUIRED FOR THE OFFSITE DETOUR WHEN THE DETOUR IS NOT IN OPERATION.

- E) ENSURE ALL NECESSARY SIGNING IS IN PLACE PRIOR TO ALTERING ANY TRAFFIC PATTERN.

TRAFFIC CONTROL DEVICES

- F) PLACE TYPE III BARRICADES, WITH "ROAD CLOSED" SIGN R11-2 ATTACHED, OF SUFFICIENT LENGTH TO CLOSE ENTIRE ROADWAY.

PAVEMENT MARKINGS AND MARKERS

- G) STATE FORCES WILL INSTALL PAVEMENT MARKINGS AND PAVEMENT MARKERS ON THE FINAL SURFACE.

PHASING NOTES

TRAFFIC CONTROL PHASING

NOTE: COORDINATE WITH THE ENGINEER FOR INSTALLATION AND REMOVAL OF ALL SIGNING AND TRAFFIC CONTROL DEVICES.

NOTE: MAINTAIN ACCESS TO DRIVEWAYS WITHIN PROJECT LIMITS AT ALL TIMES.

STEP 1: USING RSD 1101.01, SHEET 3 OF 3, INSTALL ADVANCE WORK ZONE WARNING SIGNS ON POPE ROAD (SR 1639).

STEP 2: USING RSD 1101.03, SHEET 1 OF 9 AND SHEET TMP-2, INSTALL DETOUR SIGNS AND BARRICADES AND CLOSE POPE ROAD (SR 1639).

STEP 3: REMOVE EXISTING BRIDGE NO. 315 AND CONSTRUCT PROPOSED BRIDGE AND ROADWAY, UP TO AND INCLUDING THE FINAL LAYER OF SURFACE COURSE. (NOTE: COORDINATE WITH STATE FORCES TO INSTALL FINAL PAVEMENT MARKINGS AND MARKERS ONCE CONSTRUCTION IS COMPLETE.)

STEP 4: REMOVE ALL ADVANCE WORK ZONE DETOUR SIGNS, AND TRAFFIC CONTROL DEVICES AND OPEN POPE ROAD (SR 1639) TO TRAFFIC.

PROJ. REFERENCE NO.	SHEET NO.
17BP.10.R.64	TMP-1B
 HDR Engineering, Inc. of the Carolinas 555 Fayetteville St. Suite 900 Raleigh, N.C. 27601 N.C.B.E.L.S. License Number: F-0116	

PLOT DRIVER: NCDOT_pdf_color_eng_50.ppt PENTABLE: NCDOT_tcp.tbl
 USER: DWAINWRI DATE: 2/23/2016 TIME: 1:43:56 PM
 FILE: pw\WPAPP\PA01\SouthEast_Tampa\Documents\000166\CON082236\00000000221869\06.00_TIP_Folder_Structure\17BP.10.R.64\TrafficControl\TCP\17BP-10R64_TCP_DSN.dgn

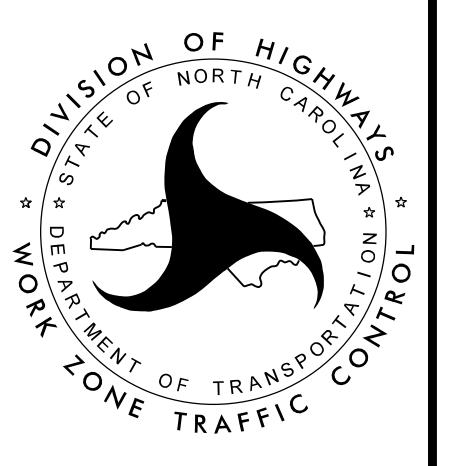
APPROVED: <i>Michelle Ward</i> <small>Michelle Ward, P.E., P.T.C.I.</small> DATE: Feb 29, 2016			<h3>GENERAL NOTES AND PHASING</h3>
DOCUMENT NOT CONSIDERED FINAL UNLESS ALL SIGNATURES COMPLETED			

PLOT DRIVER: NCDOT_paf_color_eng_50.pit
 USER: DWAINWRI
 FILE: p:\PWPPTPA01\SouthEast_Tampa_Documents\000166\CONC082236\0000000021869\06.00_TIP_Folder_Structure\17BP.10.R.64\TrafficControl\TCP\17BP-10R64_TCP_DSN.dgn
 PENTABLE: NCDOT_tcp.tbl
 DATE: 2/23/2016
 TIME: 1:43:57 PM

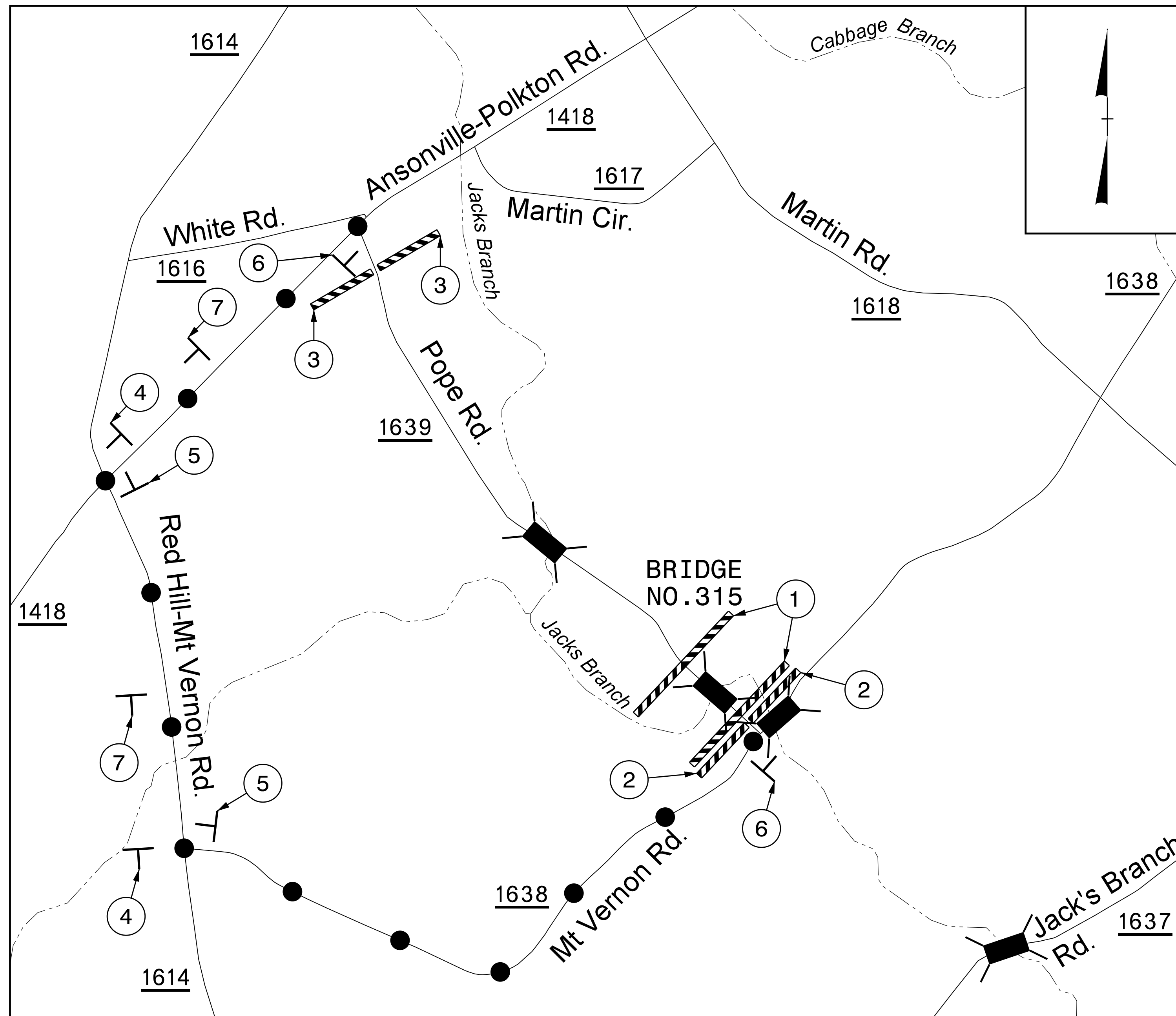

REFER TO RSD 1101.03 SHEET 1 OF 9 FOR
 ADDITIONAL SIGN AND BARRICADE PLACEMENT

PROJ. REFERENCE NO. 17BP.10.R.64	SHEET NO. TMP-2
HDR Engineering, Inc. of the Carolinas 555 Fayetteville St, Suite 900 Raleigh, N.C. 27601 N.C.B.E.L.S. License Number: F-0116	

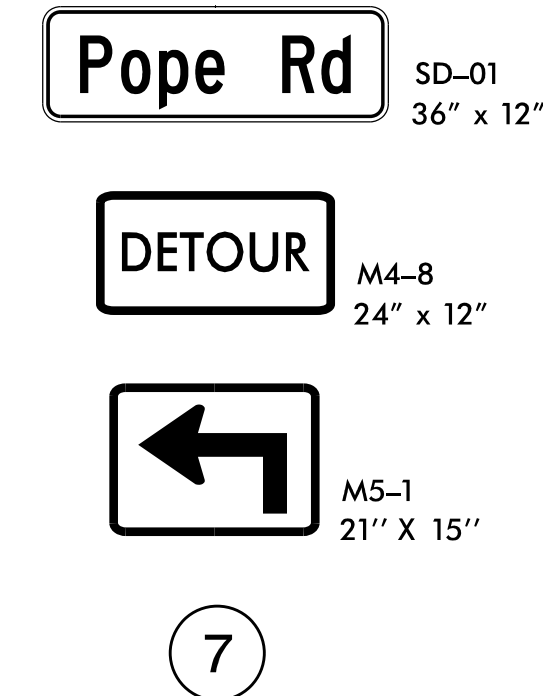
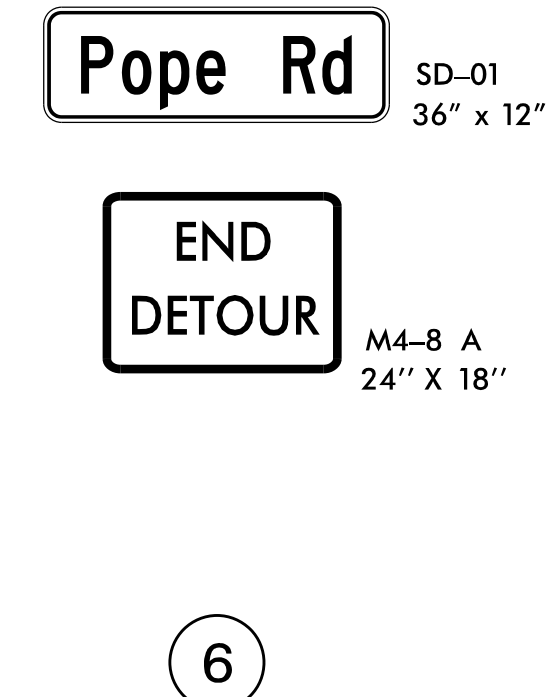
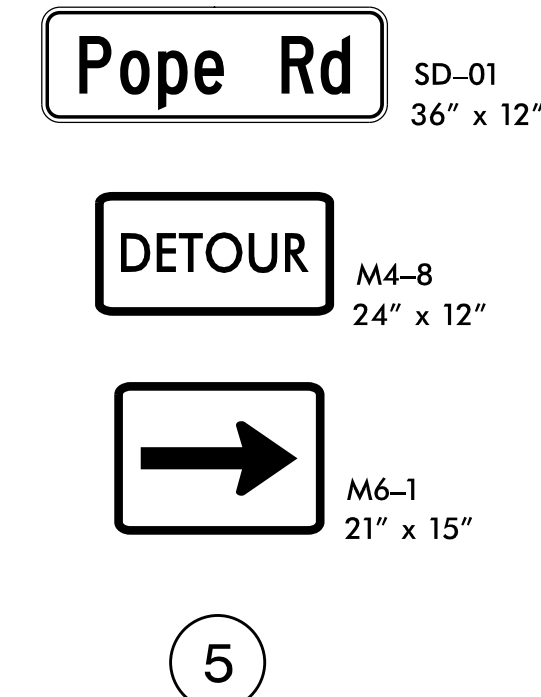
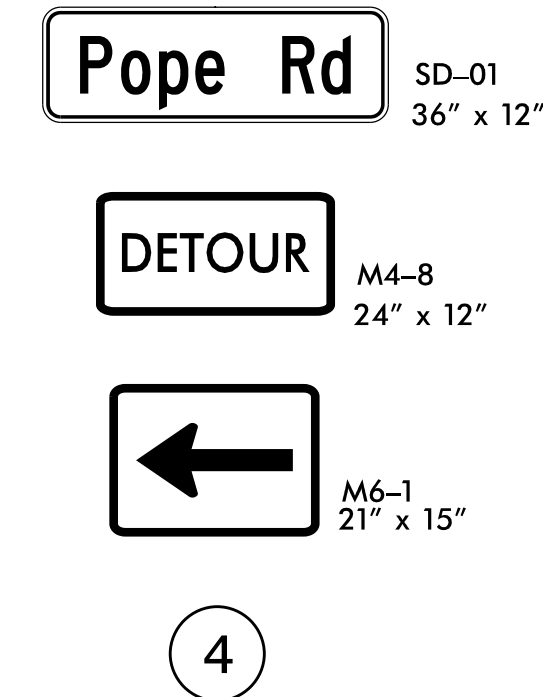
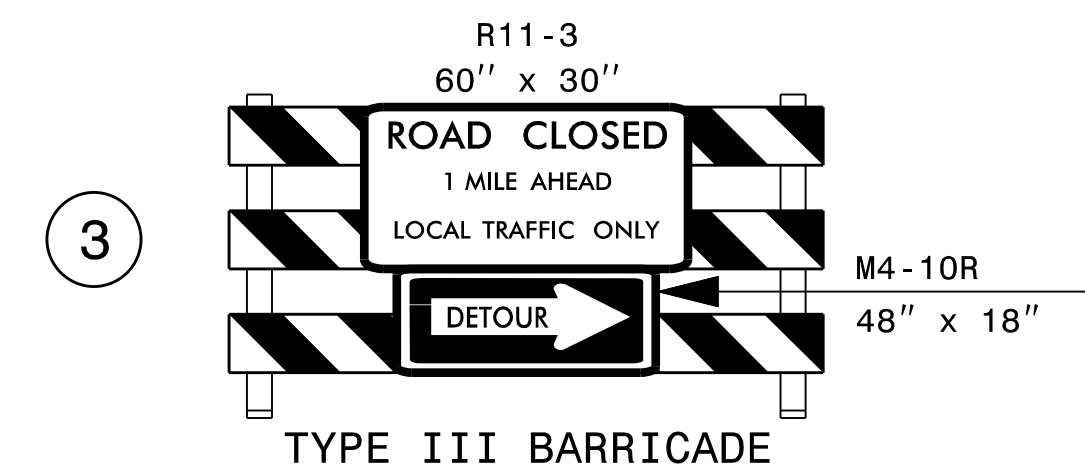
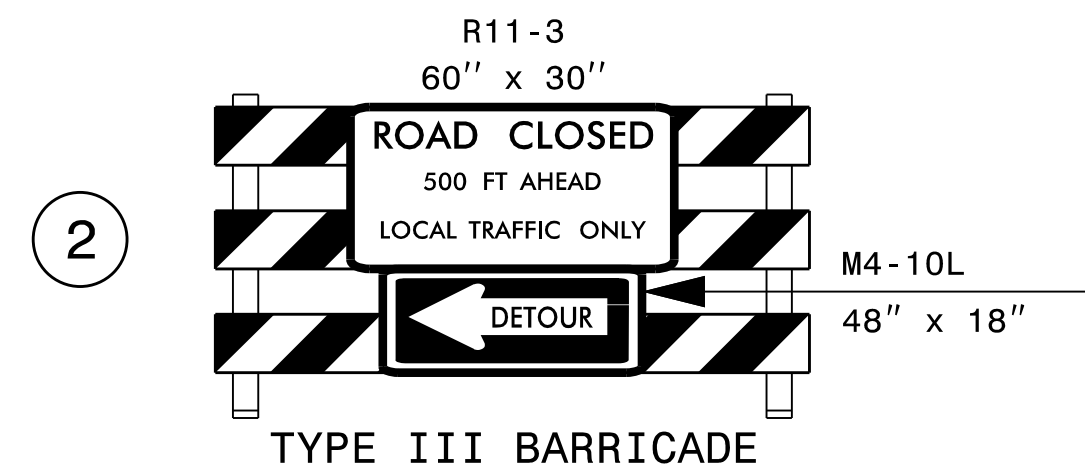
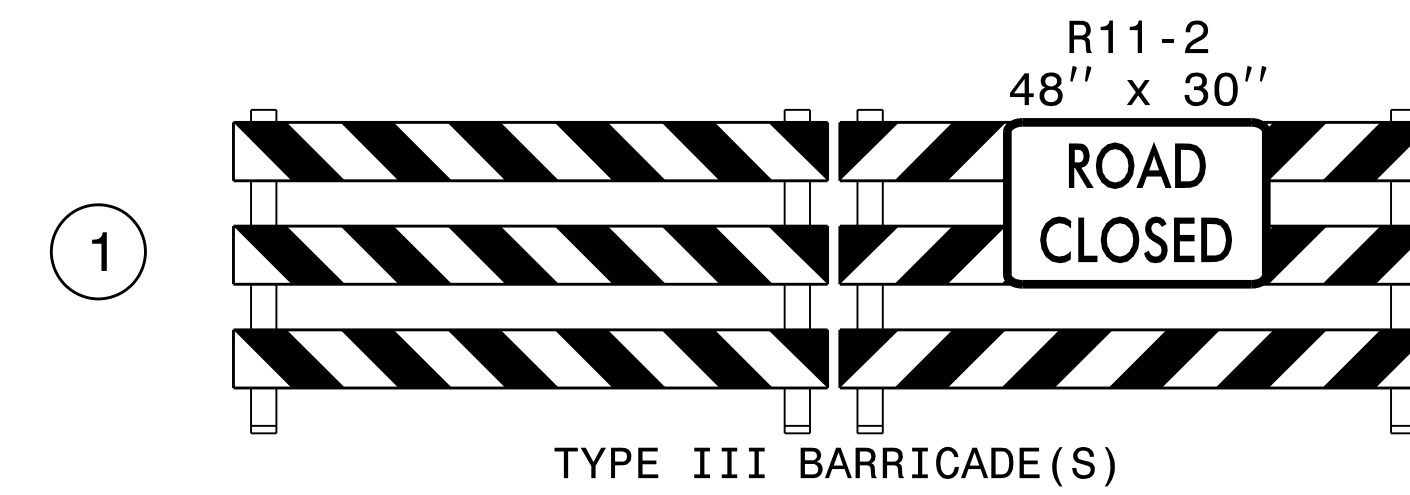

SEE SHEET SD-01 FOR
 SPECIAL SIGN DESIGN DETAIL

APPROVED: *Michelle Ward*
 DATE: Feb 29, 2016

DOCUMENT NOT CONSIDERED FINAL
 UNLESS ALL SIGNATURES COMPLETED

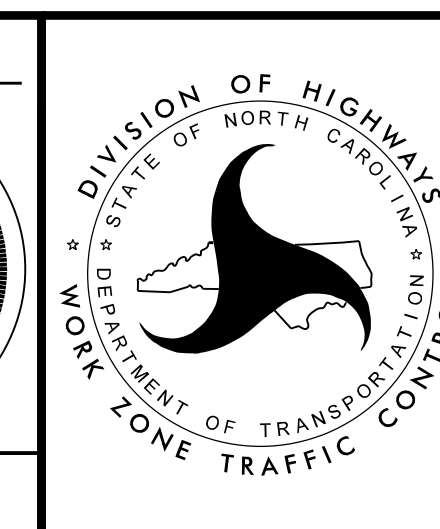

OFFSITE DETOUR PLAN
 POPE ROAD
 (SR 1639)

09/08/99

STATE PROJECT: 17BP.10.R.64

HDR HDR Engineering, Inc. of the Carolinas
3733 National Drive, Suite 207 Raleigh, N.C. 27612
N.C.B.E.L.S. License Number: F-0116

THESE EROSION AND SEDIMENT CONTROL PLANS COMPLY WITH THE REGULATIONS SET FORTH BY THE NCG-010000 GENERAL CONSTRUCTION PERMIT EFFECTIVE AUGUST 3, 2011 ISSUED BY THE NORTH CAROLINA DEPARTMENT OF ENVIRONMENT AND NATURAL RESOURCES DIVISION OF WATER QUALITY.

RYAN BROWN
LEVEL III NAME

3541
LEVEL III CERTIFICATION NO.

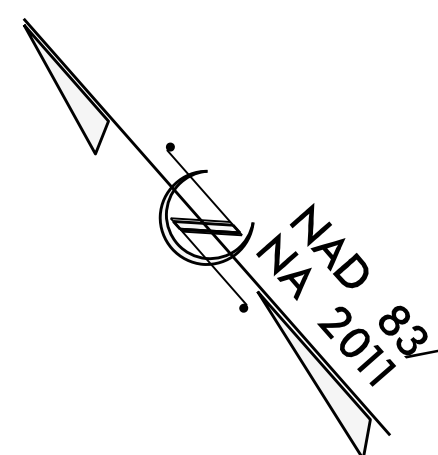

STATE OF NORTH CAROLINA
DIVISION OF HIGHWAYS
PLAN FOR PROPOSED
HIGHWAY EROSION CONTROL
ANSON COUNTY

LOCATION: BRIDGE NO. 315 ON SR 1639 OVER JACKS BRANCH
BETWEEN SR 1418 AND SR 1638

TYPE OF WORK: GRADING, DRAINAGE, PAVING AND STRUCTURE

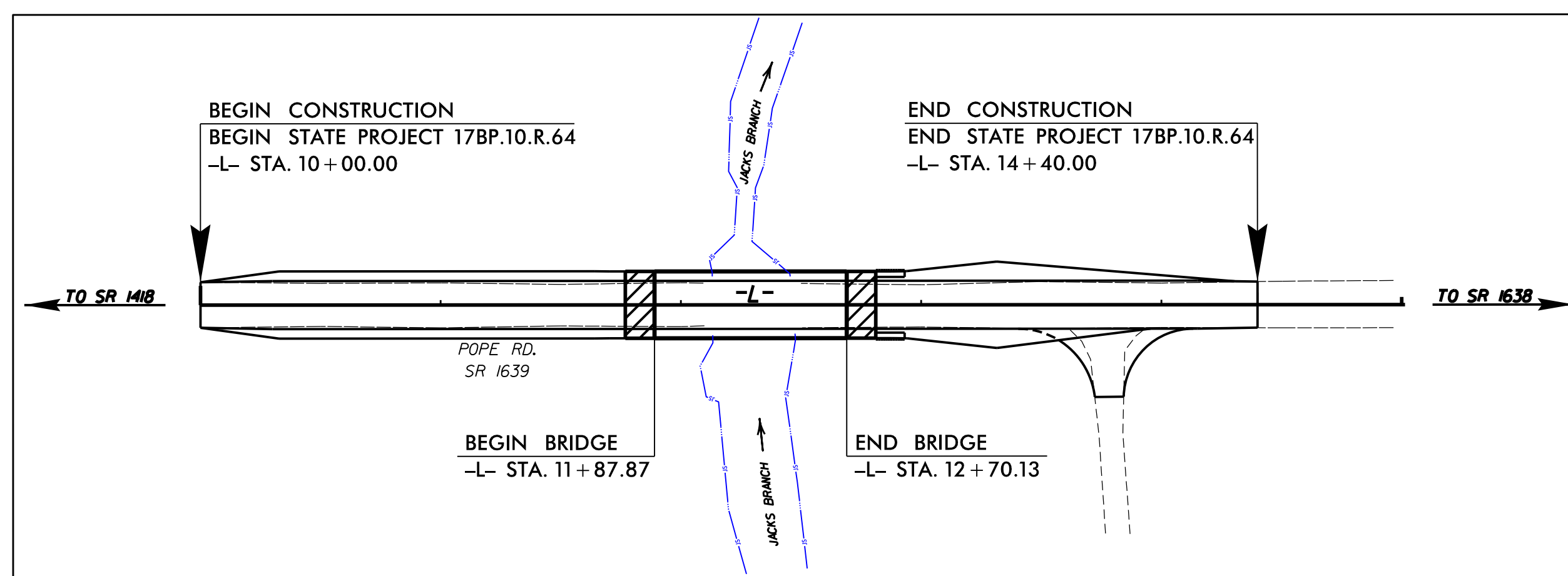

LOCATION SKETCH

CLEARING ON THIS PROJECT SHALL BE PERFORMED TO THE LIMITS ESTABLISHED BY METHOD II

GRAPHIC SCALE

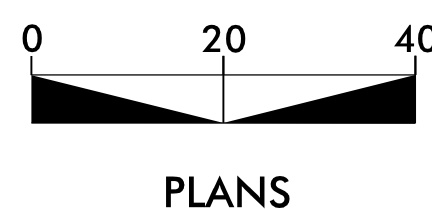

PLANS

ROADSIDE ENVIRONMENTAL UNIT
DIVISION OF HIGHWAYS
STATE OF NORTH CAROLINA

THESE EROSION AND SEDIMENT CONTROL PLANS COMPLY WITH THE REGULATIONS SET FORTH BY THE NCG-010000 GENERAL CONSTRUCTION PERMIT EFFECTIVE AUGUST 3, 2011 ISSUED BY THE NORTH CAROLINA DEPARTMENT OF ENVIRONMENT AND NATURAL RESOURCES DIVISION OF WATER QUALITY.

Prepared in the Office of:
ROADSIDE ENVIRONMENTAL UNIT
1 South Wilmington St.
Raleigh, NC 27611
2012 STANDARD SPECIFICATIONS

Roadway Standard Drawings

The following roadway english standards as appear in "Roadway Standard Drawings"- Roadway Design Unit - N. C. Department of Transportation - Raleigh, N. C., dated January 2012 and the latest revision thereto are applicable to this project and by reference hereby are considered a part of these plans.

1604.01 Railroad Erosion Control Detail	1632.01 Rock Inlet Sediment Trap Type A
1605.01 Temporary Silt Fence	1632.02 Rock Inlet Sediment Trap Type B
1606.01 Special Sediment Control Fence	1632.03 Rock Inlet Sediment Trap Type C
1607.01 Gravel Construction Entrance	1633.01 Temporary Rock Silt Check Type A
1622.01 Temporary Berms and Slope Drains	1633.02 Temporary Rock Silt Check Type B
1630.01 Riser Basin	1634.01 Temporary Rock Sediment Dam Type A
1630.02 Silt Basin Type B	1634.02 Temporary Rock Sediment Dam Type B
1630.03 Temporary Silt Ditch	1635.01 Rock Pipe Inlet Sediment Trap Type A
1630.04 Stilling Basin	1635.02 Rock Pipe Inlet Sediment Trap Type B
1630.05 Temporary Diversion	1640.01 Coir Fiber Baffle
1630.06 Special Stilling Basin	1645.01 Temporary Stream Crossing
1631.01 Matting Installation	

STATE	STATE PROJECT REFERENCE NO.	SHEET NO.	TOTAL SHEETS
N.C.	17BP.10.R.64	EC-1	
STATE PROJ. NO.	F.A. PROJ. NO.	DESCRIPTION	
17BP.10.R.64		P.E., R/W, CONSTR.	

EROSION AND SEDIMENT CONTROL MEASURES

Std. #	Description	Symbol
1630.05	Temporary Silt Ditch	
1630.05	Temporary Diversion	
1605.01	Temporary Silt Fence	
1606.01	Special Sediment Control Fence	
1622.01	Temporary Berms and Slope Drains	
1630.02	Silt Basin Type B	
1633.01	Temporary Rock Silt Check Type-A	
	Temporary Rock Silt Check Type-A with Matting and Polyacrylamide (PAM)	
1633.02	Temporary Rock Silt Check Type-B	
	Wattle / Coir Fiber Wattle	
	Wattle / Coir Fiber Wattle with Polyacrylamide (PAM)	
1634.01	Temporary Rock Sediment Dam Type-A	
1634.02	Temporary Rock Sediment Dam Type-B	
1635.01	Rock Pipe Inlet Sediment Trap Type-A	
1635.02	Rock Pipe Inlet Sediment Trap Type-B	
1630.04	Stilling Basin	
1630.06	Special Stilling Basin	
	Rock Inlet Sediment Trap:	
	Type A	
	Type B	
	Type C	
	Skimmer Basin	
	Tiered Skimmer Basin	
	Infiltration Basin	

THIS PROJECT CONTAINS EROSION CONTROL PLANS FOR CLEARING AND GRUBBING PHASE OF CONSTRUCTION.

NOTES: ANY DEVIATION FROM OPTIONS GIVEN WILL REQUIRE PRIOR APPROVAL BY ENGINEER.

ADDITIONAL EROSION CONTROL DEVICES MAY NEED TO BE INSTALLED AS DIRECTED BY THE ENGINEER.

CONTRACT:

1/26/2015 17BP.10.R.64-EC-PLANSHEETS 3:55:25 PM

TEMPORARY ROCK SILT CHECK TYPE 'A' WITH EXCELSIOR MATTING AND POLYACRYLAMIDE (PAM) DETAIL

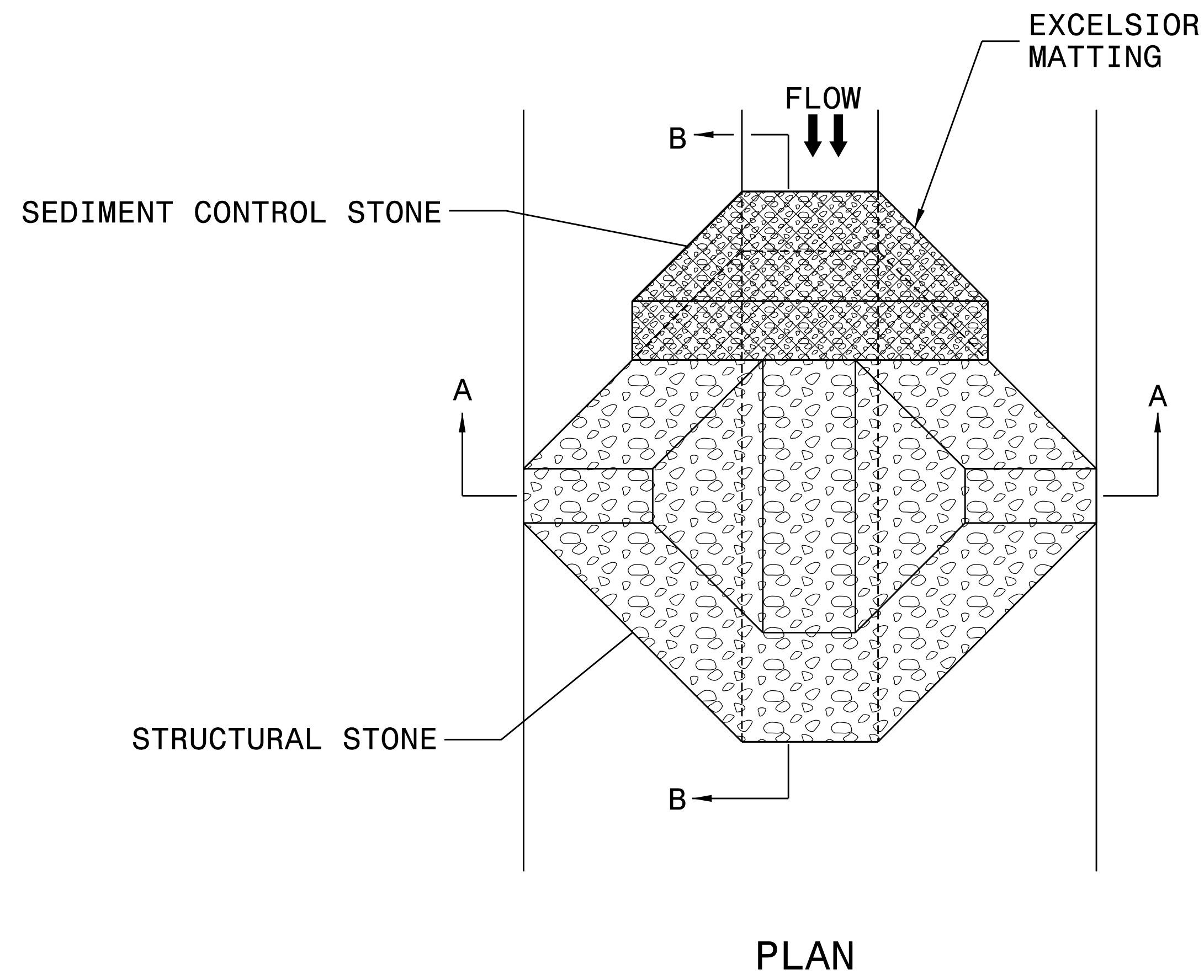

NOTES:

INSTALL TEMPORARY ROCK SILT CHECK TYPE A IN ACCORDANCE WITH ROADWAY STANDARD DRAWING NO. 1633.01.

USE EXCELSIOR FOR MATTING MATERIAL AND ANCHOR MATTING SECTION AT TOP AND BOTTOM WITH CLASS B STONE.

PRIOR TO POLYACRYLAMIDE (PAM) APPLICATION, OBTAIN A SOIL SAMPLE FROM PROJECT LOCATION, AND FROM OFFSITE MATERIAL, AND ANALYZE FOR APPROPRIATE PAM FLOCCULANT TO BE APPLIED TO EACH ROCK SILT CHECK.

INITIALLY APPLY 4 OUNCES OF POLYACRYLAMIDE (PAM) TO TOP OF MATTING SECTION AND AFTER EVERY RAINFALL EVENT THAT EQUALS OR EXCEEDS 0.50 INCHES.

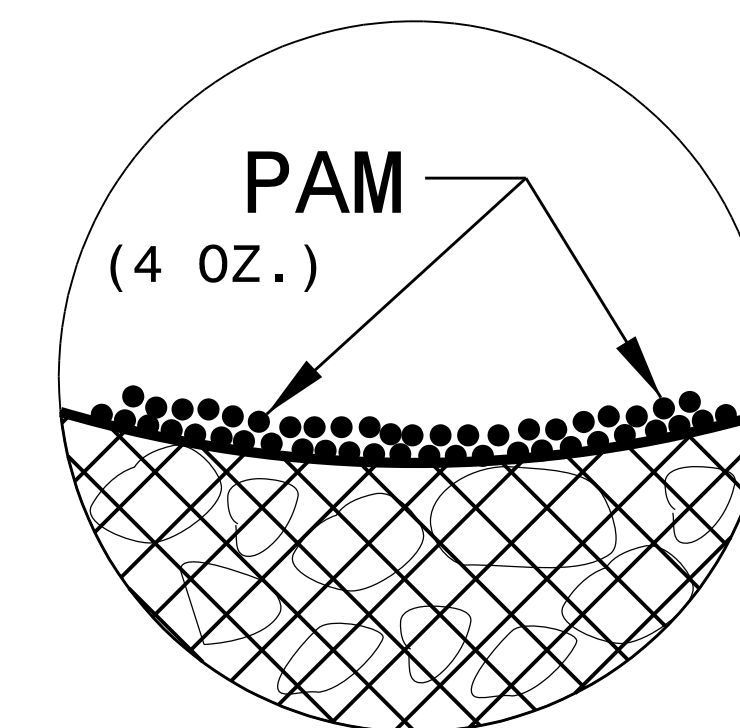

INSET A

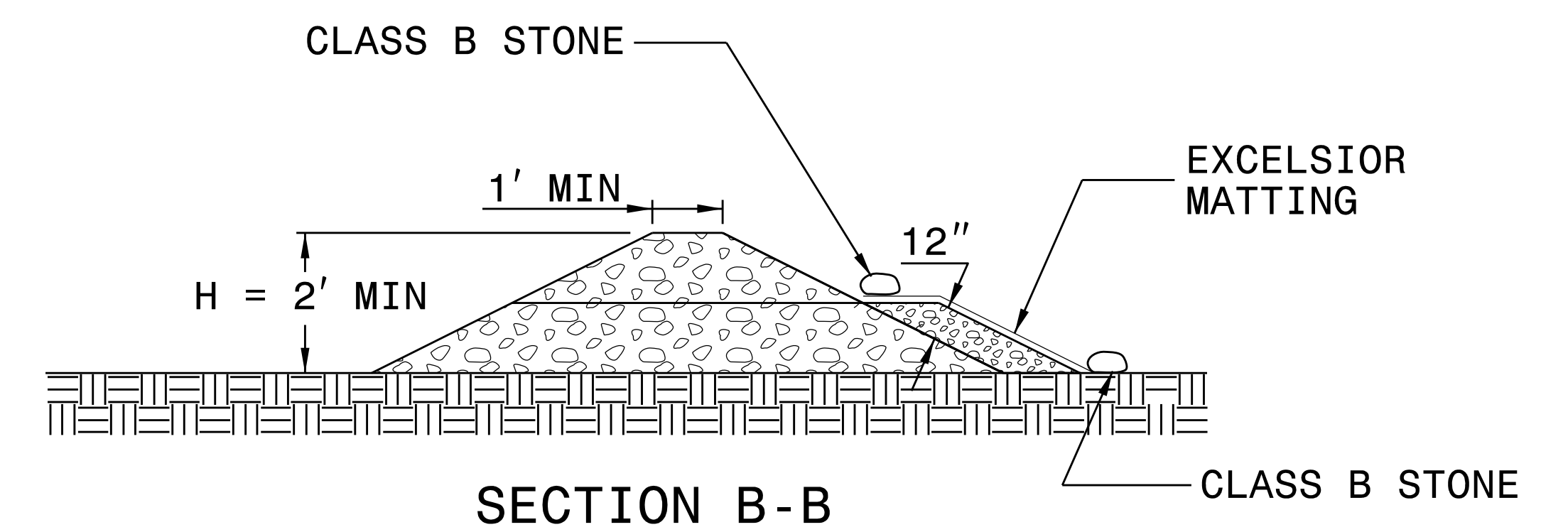
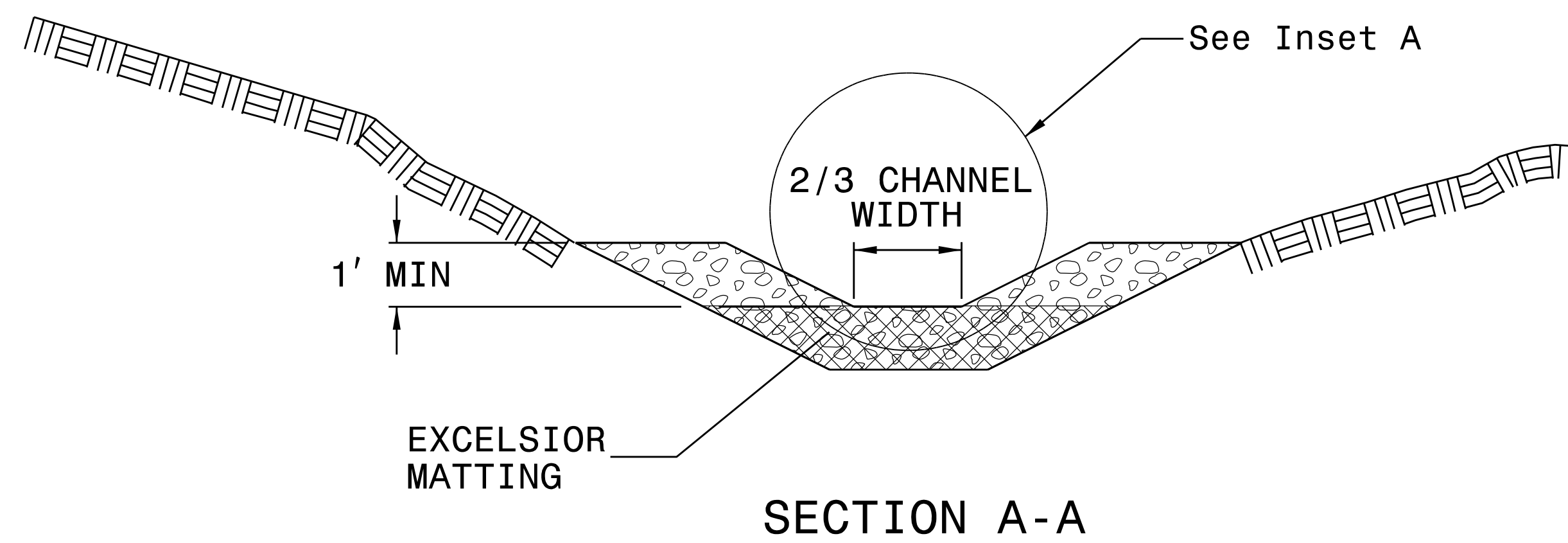

NOT TO SCALE

DIVISION OF HIGHWAYS
STATE OF NORTH CAROLINA

SOIL STABILIZATION TIMEFRAMES

<i>SITE DESCRIPTION</i>	<i>STABILIZATION TIME</i>	<i>TIMEFRAME EXCEPTIONS</i>
PERIMETER DIKES, SWALES, DITCHES AND SLOPES	7 DAYS	NONE
HIGH QUALITY WATER (HQW) ZONES	7 DAYS	NONE
SLOPES STEEPER THAN 3:1	7 DAYS	IF SLOPES ARE 10' OR LESS IN LENGTH AND ARE NOT STEEPER THAN 2:1, 14 DAYS ARE ALLOWED.
SLOPES 3:1 OR FLATTER	14 DAYS	7 DAYS FOR SLOPES GREATER THAN 50' IN LENGTH.
ALL OTHER AREAS WITH SLOPES FLATTER THAN 4:1	14 DAYS	NONE, EXCEPT FOR PERIMETERS AND HQW ZONES.

USE BEST MANAGEMENT PRACTICES TO CONTAIN ANY ERODABLE MATERIAL DURING INSTALLATION OF WATER LINE THROUGH JURISDICTIONAL AREA.

CLEARING AND GRUBBING EROSION CONTROL FOR CONSTRUCTION SHEET 4

PROJECT REFERENCE NO.	SHEET NO.
17BP.10.R.64	EC-4
RW SHEET NO.	
 HDR Engineering, Inc. of the Carolinas 3733 National Drive, Suite 207 Raleigh, N.C. 27612 N.C.B.E.L.S. License Number: F-0116	

REVISIONS

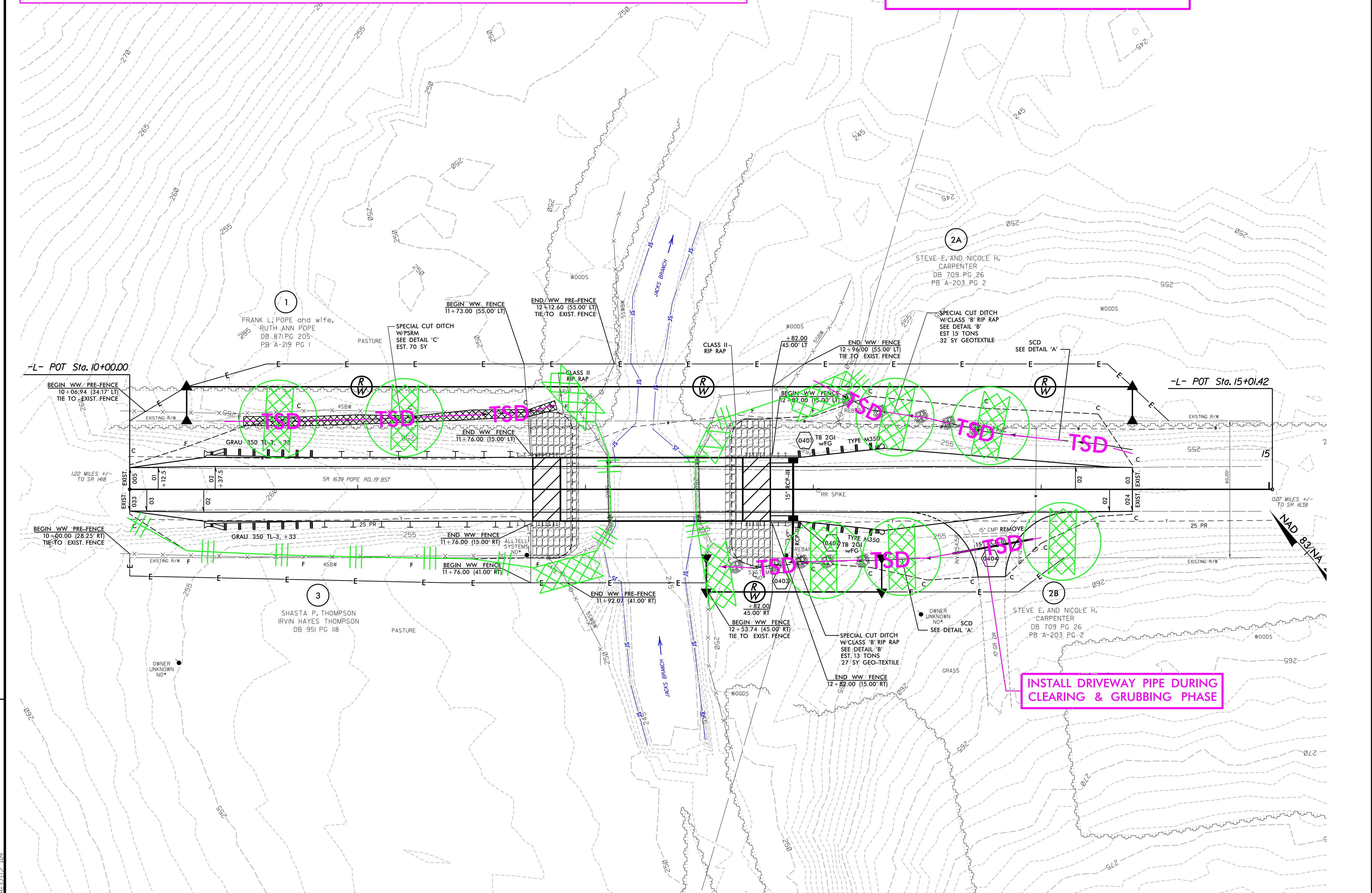

INSTALL DRIVEWAY PIPE DURING CLEARING & GRUBBING PHASE

12/1/2014 10:10:10 AM
 17BP.10.R.64_EC_PLANSHEETS
 11:37:15 AM

09/08/14

STATE PROJECT: 17BP.10.R.64

CONTRACT: -

T.I.P. NO.	SHEET NO.
17BP.10.R.64	UC-1

STATE OF NORTH CAROLINA
DIVISION OF HIGHWAYS

UTILITY CONSTRUCTION PLANS
ANSON COUNTY

LOCATION: BRIDGE NO. 315 ON SR 1639 OVER JACKS BRANCH
BETWEEN SR 1418 AND SR 1638

TYPE OF WORK: UTILITY CONSTRUCTION

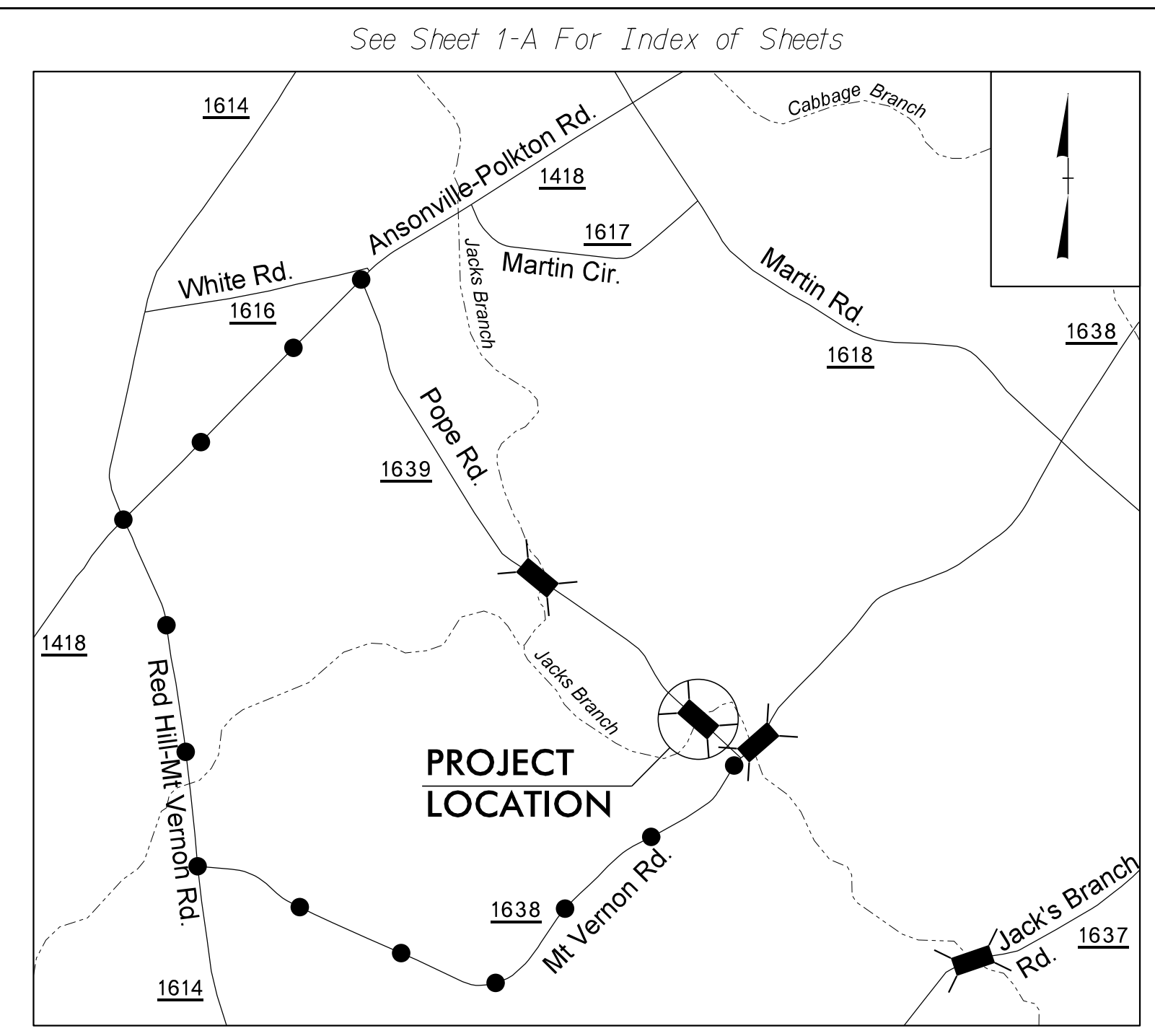

DETOUR ROUTE
VICINITY MAP
(NOT TO SCALE)

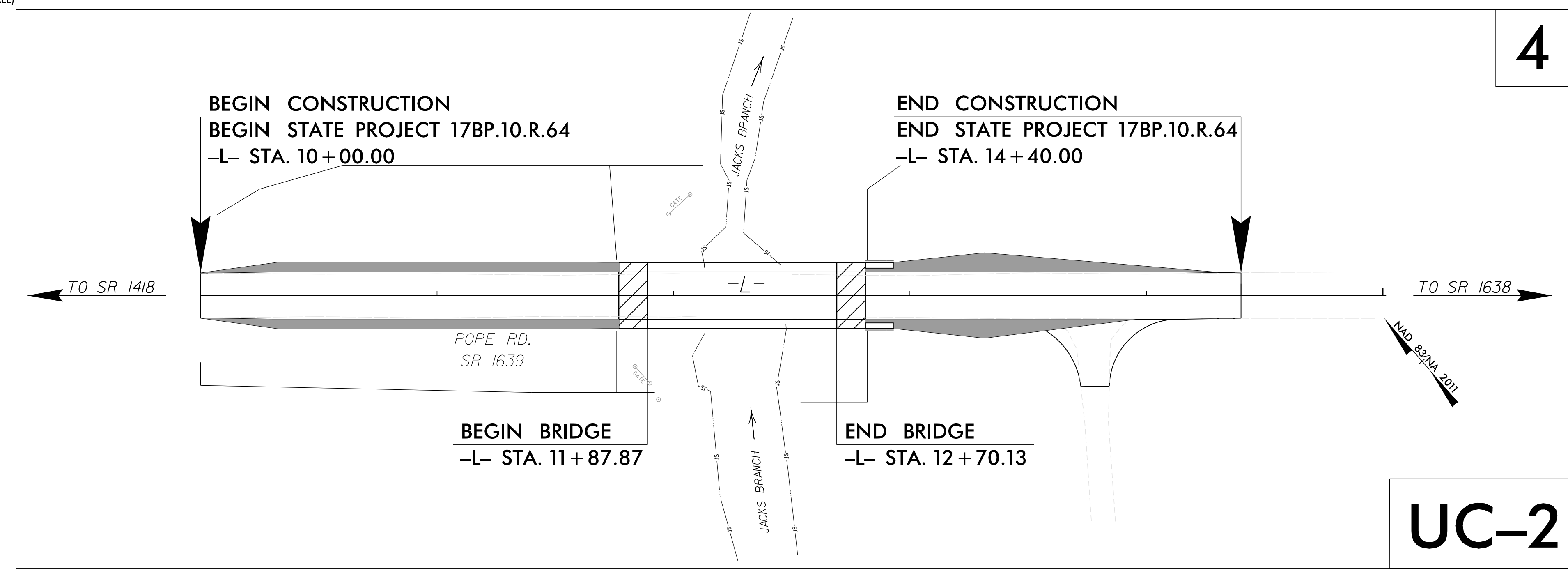
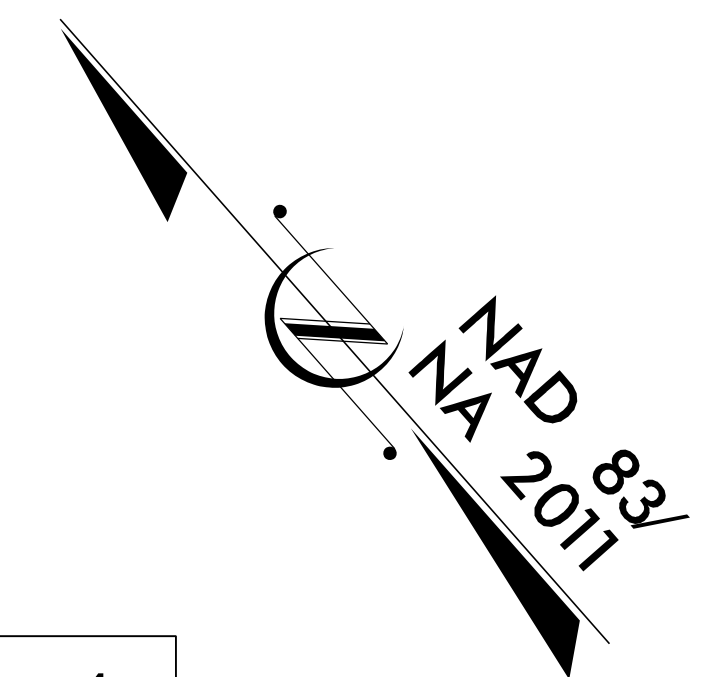

LOCATION SKETCH

UC-2

CLEARING ON THIS PROJECT SHALL BE PERFORMED TO THE LIMITS ESTABLISHED BY METHOD II

HDR HDR Engineering, Inc. of the Carolinas
3733 National Drive, Suite 207 Raleigh, N.C. 27612
N.C.B.E.L.S. License Number: F-0116

Jan 27, 2015
NORTH CAROLINA PROFESSIONAL SEAL
022321
ENGINEER
MICHAEL V. ZACCARDO
Michael V. Zaccardo
Michael V Zaccardo (Jan 27, 2015)

RELEASE FOR CONSTRUCTION
DATE: 01/23/15

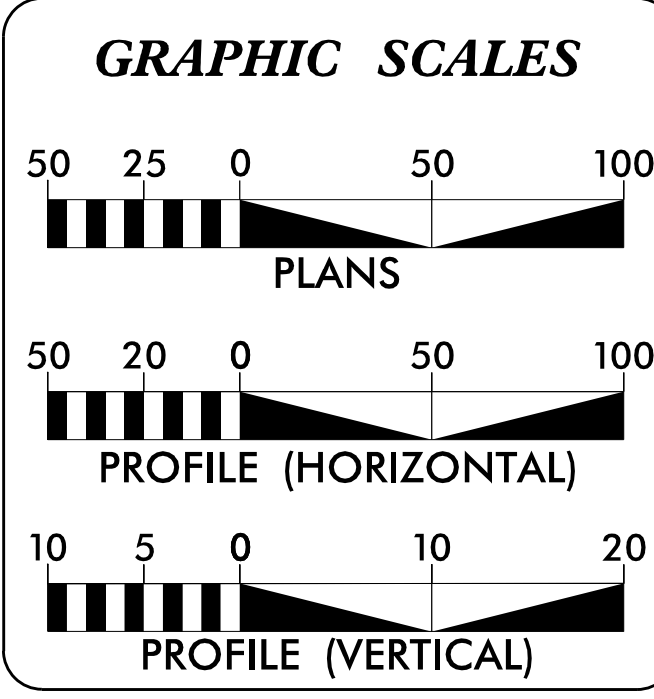

INDEX OF SHEETS

SHEET NO.	DESCRIPTION
UC-1	TITLE SHEET
UC-2	PLAN & PROFILE SHEET

WATER AND SEWER OWNERS ON PROJECT

(1) ANSON COUNTY (WATER)

Prepared for HDR Engineering, Inc. in the Office of:
ETHERILL ENGINEERING
559 JONES FRANKLIN ROAD
SUITE 164
Raleigh, N.C. 27606
License No. F-0377
Bus: 919 851 8077
Fax: 919 851 8037

2012 STANDARD SPECIFICATIONS
RIGHT OF WAY DATE:
LETTING DATE: FEBRUARY 18, 2015
NC DOT CONTACT: ROADWAY DESIGN SPECIAL DESIGN SECTION

DOMINIC M. WAINWRIGHT, P.E.
PROJECT ENGINEER
JAMES R. RICE, P.E.
PROJECT DESIGN ENGINEER
MICHAEL V. ZACCARDO, PE
UTILITY DESIGN ENGINEER

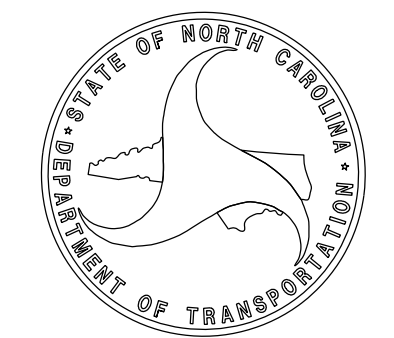

\$\$\$\$\$ SYSTEM \$\$\$\$\$\$
\$\$\$\$\$ USER NAME \$\$\$\$\$\$

8/17/99

WETHERILL ENGINEERING
 559 Jones Franklin Rd. Suite 164
 Raleigh, N.C. 27606
 License No. F-0377
 Bus: 919 851 8077
 Fax: 919 851 8107

TRANSPORTATION PLANNING/DESIGN - BRIDGE/STRUCTURE DESIGN
 CIVIL/SITE DESIGN - GIS/GPS - CONSTRUCTION OBSERVATION

PROJECT REFERENCE NO.	SHEET NO.
17BP.10.R.64	UC-2
DESIGNED BY: JDS	
DRAWN BY: JDS	
CHECKED BY: MVZ	
APPROVED BY: MVZ	
REVISED:	
NORTH CAROLINA DEPARTMENT OF TRANSPORTATION	
UTILITIES ENGINEERING SEC. PHONE: (919) 707-6690 FAX: (919) 250-4151	
MICHAEL V. ZACCARLO ENGINEER LICENSE NO. 27,2015 SEAL 022321 MICHAEL V. ZACCARLO UTILITY CONSTRUCTION PLANS ONLY	

RELEASE FOR CONSTRUCTION
 DATE: 01/23/15

UTILITY CONSTRUCTION

HDR HDR Engineering, Inc. of the Carolinas
 3733 National Drive, Suite 207 Raleigh, N.C. 27612
 N.C.B.E.L.S. License Number: F-0116

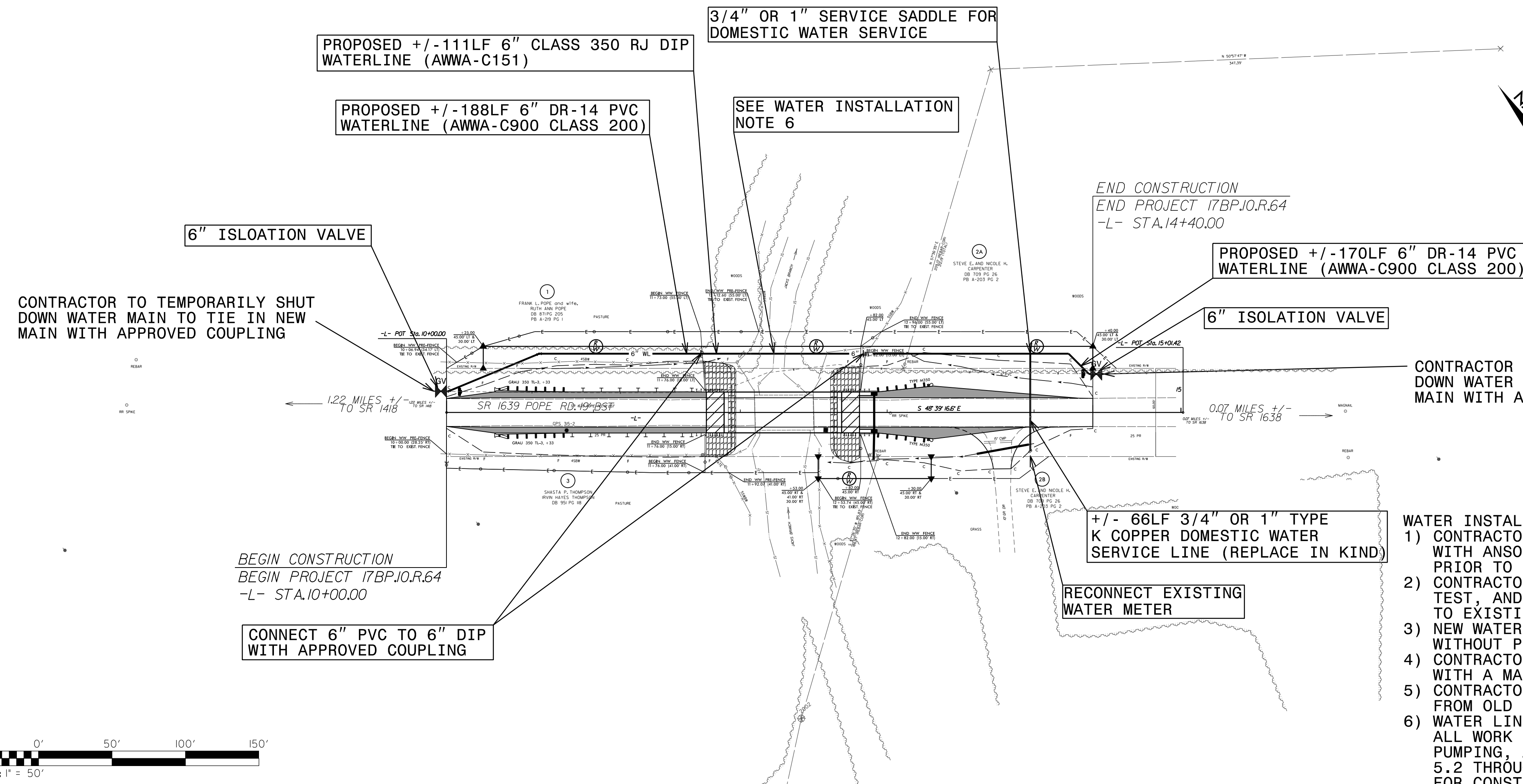

- GENERAL INSTALLATION NOTES:**
- 1) ALL WORK SHALL BE IN ACCORDANCE WITH: ANSON COUNTY UTILITY STANDARDS
 NCDENR DEH PWS SECTION STANDARDS
- WATER INSTALLATION NOTES:**
- 1) CONTRACTOR SHALL COORDINATE ALL PROPOSED WORK WITH ANSON COUNTY PUBLIC WORKS DIRECTOR PRIOR TO BEGINNING WORK.
 - 2) CONTRACTOR SHALL FULLY INSTALL, PRESSURE & LEAKAGE TEST, AND CHLORINATE NEW WATER MAIN PRIOR TO CONNECTION TO EXISTING SYSTEM.
 - 3) NEW WATER MAIN SHALL NOT TO BE CONNECTED TO EXISTING MAIN WITHOUT PRIOR APPROVAL AND COORDINATION WITH ANSON COUNTY UTILITIES.
 - 4) CONTRACTOR SHALL PERFORM THE CONNECTION DURING PEAK HOURS WITH A MAXIMUM SHUT DOWN TIME OF SIX HOURS.
 - 5) CONTRACTOR SHALL TAP NEW MAIN AND RELOCATE EXISTING WATER SERVICES FROM OLD MAIN.
 - 6) WATER LINE SHALL BE INSTALLED BY OPEN CUT THROUGH THE STREAM CHANNEL. ALL WORK SHALL BE CONDUCTED IN THE DRY. IMPERVIOUS DIKES, BYPASS PUMPING, AND DEWATERING ACTIVITIES SHALL BE IN ACCORDANCE TO SECTIONS 5.2 THROUGH 5.4 OF THE NORTH CAROLINA DEPARTMENT OF TRANSPORTATION BMP FOR CONSTRUCTION AND MAINTENANCE ACTIVITIES. (DATED 8/2003)

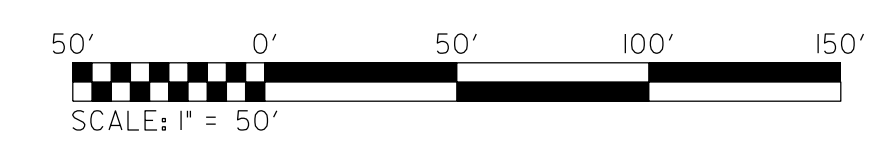

REVISIONS

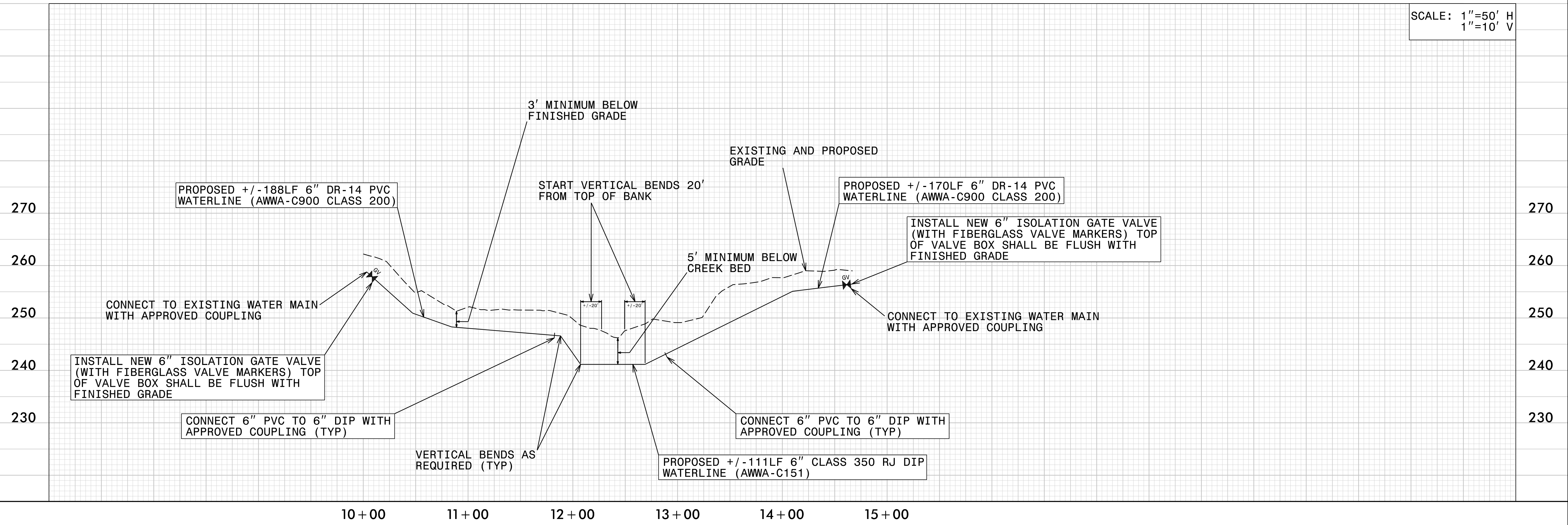

SCALE: 1"=50' H
 1"=10' V

15:26 AM
 1/26/2015
 Division 10 Anson 030315Utilities(Rdy_Ut\Proj\17BP-10R64_ut_rdy4_uc2_psh RFC_150123.DGN

09.08.14

STATE PROJECT: 17BP.10.R.64

CONTRACT: -

SYSTEMS
SERVICES

See Sheet 1-A For Index of Sheets

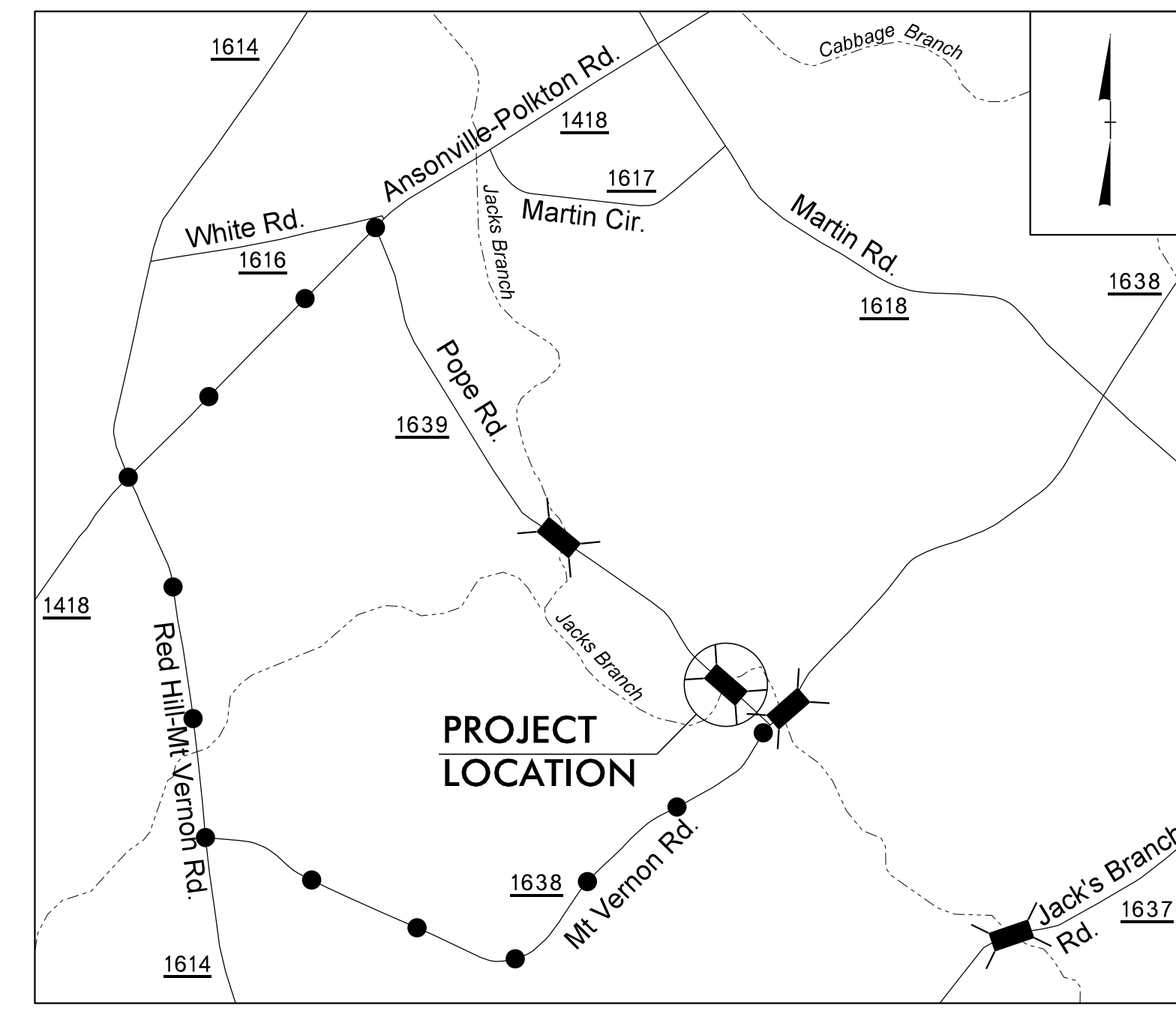

DETOUR ROUTE
VICINITY MAP
(NOT TO SCALE)

STATE OF NORTH CAROLINA DIVISION OF HIGHWAYS

UTILITIES BY OTHERS ANSON COUNTY

LOCATION: BRIDGE NO. 315 ON SR 1639 OVER JACKS BRANCH
BETWEEN SR 1418 AND SR 1638

TYPE OF WORK: UTILITY RELOCATION

T.I.P. NO.	SHEET NO.
17BP.10.R.64	UO-1

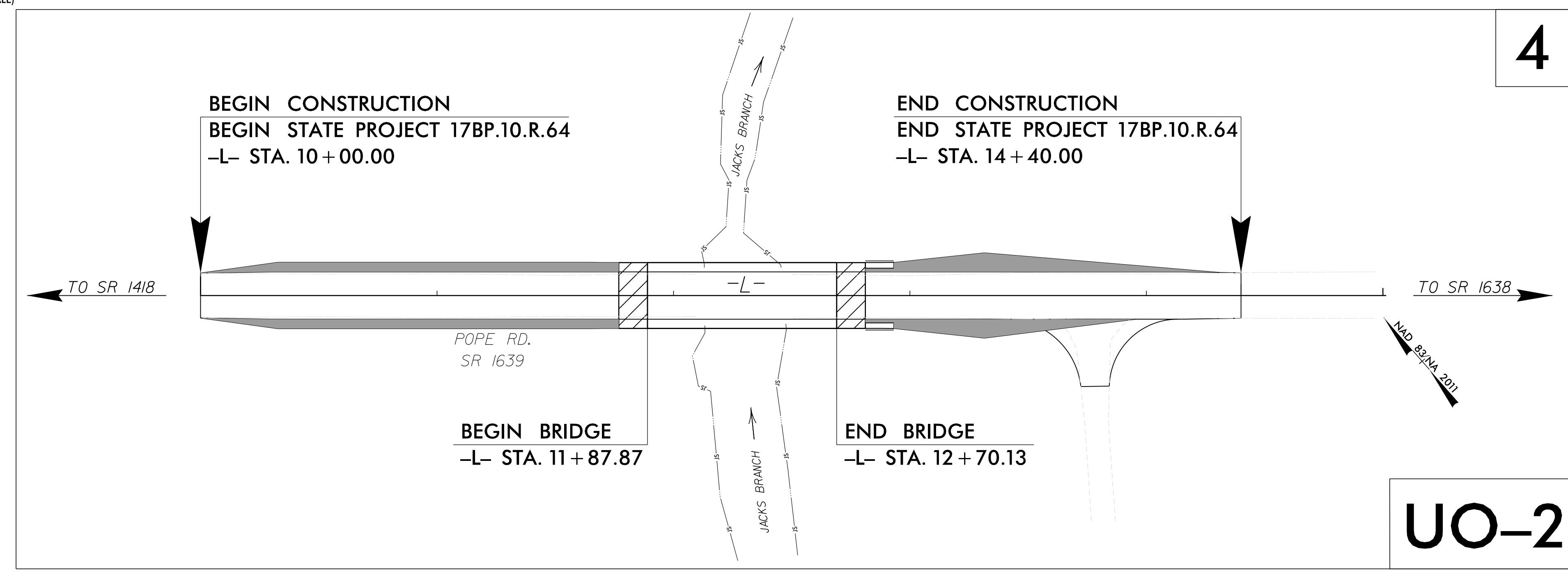
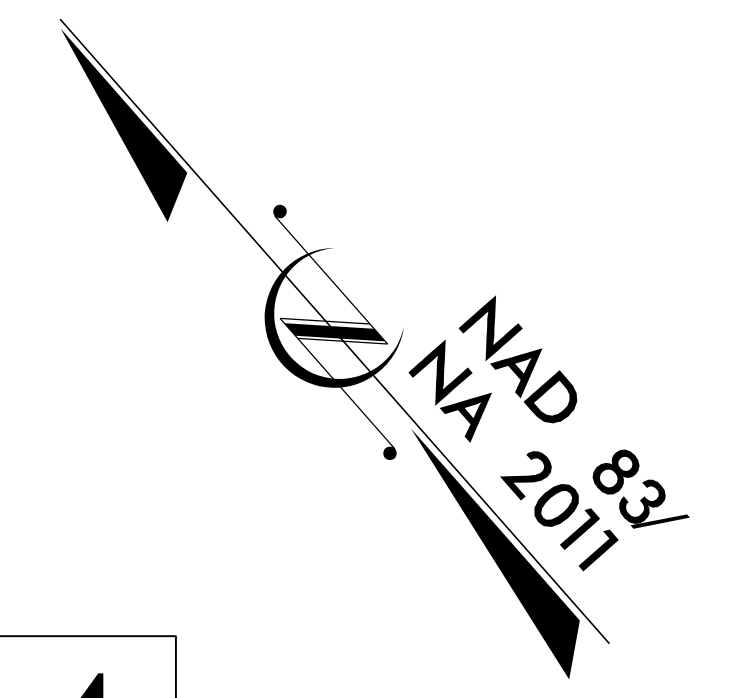

LOCATION SKETCH

CLEARING ON THIS PROJECT SHALL BE PERFORMED TO THE LIMITS ESTABLISHED BY METHOD II

HDR HDR Engineering, Inc. of the Carolinas
3733 National Drive, Suite 207 Raleigh, N.C. 27612
N.C.B.E.L.S. License Number: F-0116

RELEASE FOR
CONSTRUCTION
DATE: 01/23/15

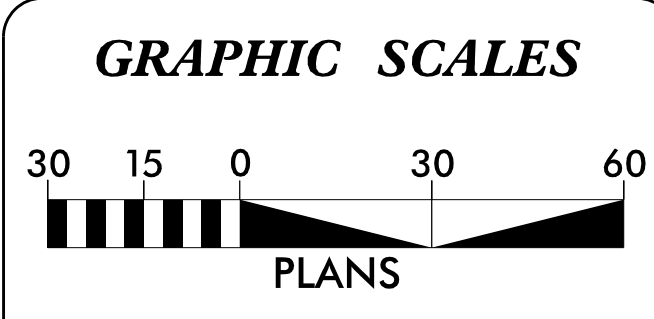

SHEET NO.	DESCRIPTION
UO-1	TITLE SHEET
UO-2	PLAN SHEET

UTILITY OWNERS ON PROJECT

(A) WINDSTREAM (TELEPHONE)
(B) PEE DEE EMC (POWER - DISTRIBUTION)

Prepared for HDR Engineering, Inc.
in the Office of:

ETHERILL ENGINEERING
559 JONES FRANKLIN ROAD
SUITE 164
Raleigh, N.C. 27606
License No. F-0377
Bus: 919 851 8077
Fax: 919 851 8037

2012 STANDARD SPECIFICATIONS

RIGHT OF WAY DATE: _____

LETTING DATE:
FEBRUARY 18, 2015

NC DOT CONTACT: _____

DOMINIC M. WAINWRIGHT, P.E.
PROJECT ENGINEER

JAMES R. RICE, P.E.
PROJECT DESIGN ENGINEER

JOHN D. SCHRINER, PLS
UTILITY COORDINATOR

ROADWAY DESIGN SPECIAL DESIGN SECTION

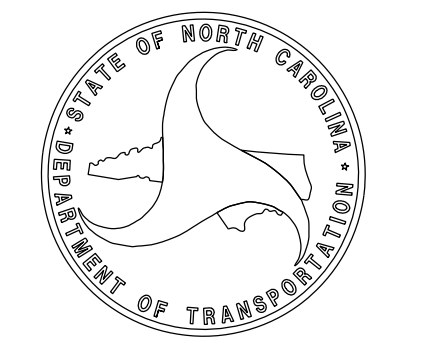

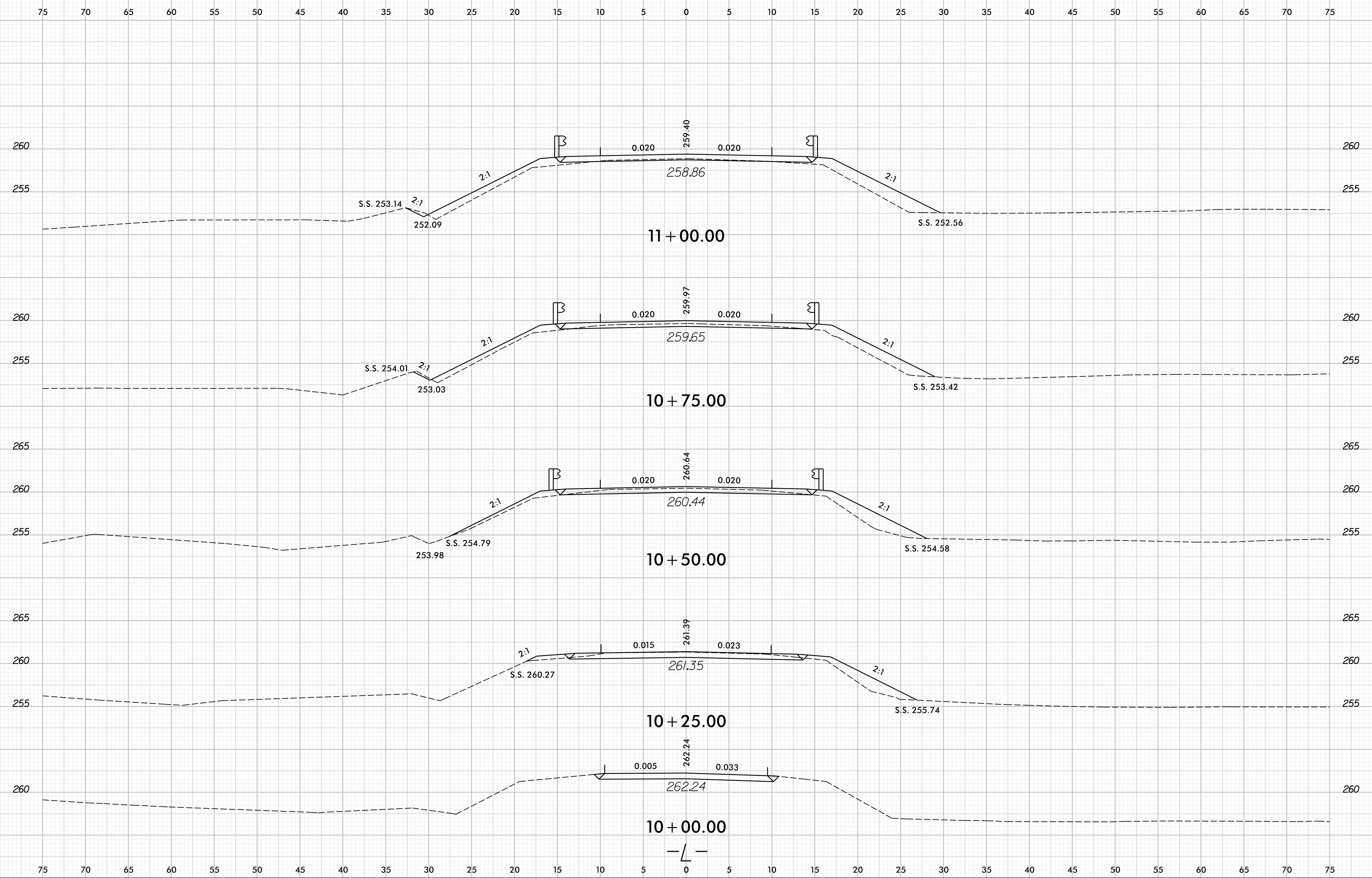

8/23/99



PROJ. REFERENCE NO.	SHEET NO.
17BP.10.R.64	X-2

75 70 65 60 55 50 45 40 35 30 25 20 15 10 5 0 5 10 15 20 25 30 35 40 45 50 55 60 65 70 75

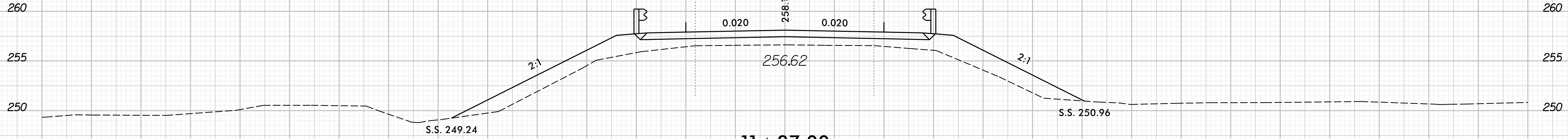

11 + 87.00

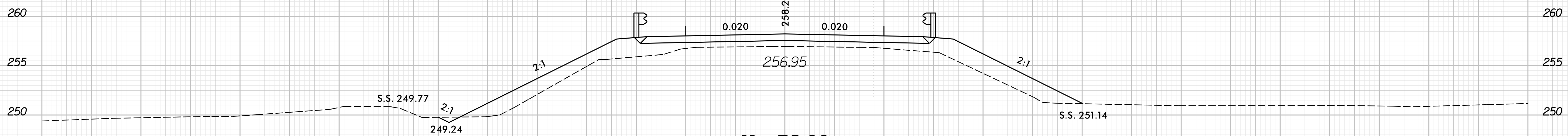

11 + 75.00

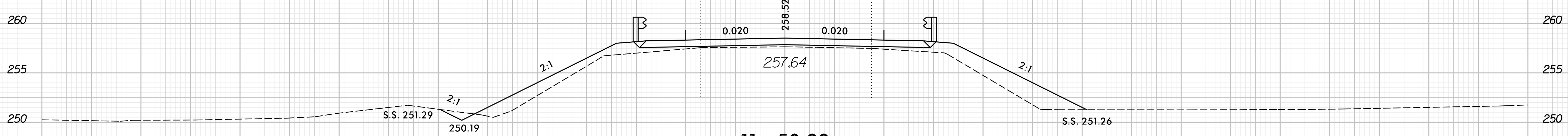

11 + 50.00

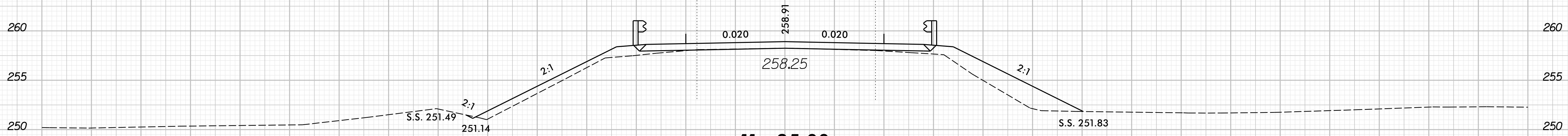

11 + 25.00

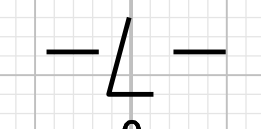

75 70 65 60 55 50 45 40 35 30 25 20 15 10 5 0 5 10 15 20 25 30 35 40 45 50 55 60 65 70 75

1/23/2015
 9:28:53 PM
 \\p0508921\17BP-10R64-RDY_XPL.DGN

